





Philips FP5 FP6 FP7





**OPERATION AND  
MAINTENANCE  
OF THE  
PHILIPS  
SOUND-FILM EQUIPMENT**

**PREFACE**

This guide contains comprehensive instructions for the operation and maintenance of Philips sound-film equipment. Attention is drawn to the fact that no claims to guarantee can be entertained if it should appear that the faults or defects are due to non-observance of these instructions.

Directions are also given in this book to facilitate the assembling and dismantling of the parts, so that in the absence of a service-engineer the operator can replace any defective parts himself; this, however, should only be done in cases of absolute necessity.

The operating instructions themselves are divided into a number of main groups, each of which contains directions for a definite group of apparatus. To simplify the use of this book each main group has been given a different colour; moreover, an illustration of the apparatus concerned is shown in the margin.

The instructions for use are printed on loose sheets to allow of the insertion of supplements.

It is emphasized that this guide is only intended for the above purposes. In view of the constructional drawings contained in them the sheets must not be handed to third parties (copyright).

The contents may not be published, either in full or in part, without our consent.

## MAIN GROUPS

A. Projectors, sound-heads, arc lamps, etc.



B. Amplifiers, loudspeakers, etc.



C. Accessories

Film spools, film re-winder, film splicer, projection room windows, picture and sound change-over switch, lenses, projection screens, arc-lamp carbons, cinema rectifiers, etc.



D. General

Wiring indications, determination of the focal length, distribution of light on the projection screen, etc.



E. Special tools and measuring instruments



A-1

1.11.47

## A PROJECTORS, SOUND-HEADS, ARC LAMPS, ETC.

### SUBDIVISION

AA. Projectors FP 5, FP 6 and FP 7



FP 5-6-7

AB. Sound-head type 3837



3837



# AA

## PROJECTORS FP 5, FP 6, FP 7

### CONTENTS

I	General description . . . . .	
II	Hints on installation . . . . .	
	§ 1. Preparing the projection room . . . . .	
	§ 2. Unpacking . . . . .	
	§ 3. Assembling the equipment . . . . .	
	§ 4. Electrical connections . . . . .	
	§ 5. Getting ready for operation . . . . .	
	§ 6. Adjusting the apparatus . . . . .	
	§ 7. Trying out the projector in operation with a film loop . . . . .	
	§ 8. Trying out the projector in operation with a film . . . . .	
III	Operation . . . . .	
	§ 1. Threading the film . . . . .	
	§ 2. Switching on . . . . .	
	§ 3. Framing . . . . .	
	§ 4. Focusing . . . . .	
	§ 5. Adjusting the pressure skates . . . . .	
	§ 6. Use of the manual loop correctors . . . . .	
IV	Maintenance . . . . .	
V	Description of the parts and their maintenance . . . . .	
	§ 1. Oil circulation in the projector . . . . .	
	§ 2. Lens holders, adapters and lenses . . . . .	
	§ 3. Pressure skates . . . . .	
	§ 4. Steel runner plate with lateral pressure piece . . . . .	
	§ 5. Velvet-covered runner plates . . . . .	
	§ 6. Intermittent sprocket . . . . .	
	§ 7. 32-tooth sprockets with manual film-loop correctors . . . . .	
	§ 8. 32-tooth sprockets without manual film-loop correctors . . . . .	
	§ 9. Pad rollers . . . . .	
	§ 10. Drum shutter . . . . .	
	§ 11. Cooling instructions . . . . .	
	§ 12. Air-cooling . . . . .	
	§ 13. Water-cooling . . . . .	
	§ 14. Automatic film-rupture device type 8669 . . . . .	
	§ 15. Top and bottom spool boxes; wedge blocks . . . . .	

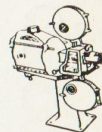

FP 5-6-7

# AA.-2

1.11.47

	§ 16. Safety fire-traps . . . . .	25	
	§ 17. Safety clutch . . . . .	26	
	§ 18. Adjustable guide roller in the FP 7 projector . . . . .	27	
VI	Dismantling the internal parts of the projector . . . . .		AA.F
	§ 1. Intermittent unit . . . . .	1	
	§ 2. Combined gauze and magnetic filter . . . . .	1	
	§ 3. Oil delivery pipe . . . . .	1	
	§ 4. Oil pump . . . . .	1	
	§ 5. Flange motor and pulley bearing plate . . . . .	1	
	§ 6. Bearing supports of the top and bottom sprockets . . . . .	1	
	§ 7. Bearing support of the shutter spindle . . . . .	1	
	§ 8. Main shaft . . . . .	1	
VII	Different motors . . . . .		AA.G
	§ 1. Converting a belt-driven projector into one with flange motor for 50 c/s mains . . . . .	1	
	§ 2. Converting a projector with flange motor into a belt-driven one for 40, 50, 60 and 100 c/s mains . . . . .	1	
	§ 3. Converting a projector with flange motor into a belt-driven one for D.C. mains . . . . .	2	
VIII	Rear projection and front projection with short focus lenses . . . . .		AA.H
IX	Equipment of the projection room . . . . .		AA.J
	§ 1. Dimensions . . . . .	1	
	§ 2. Water-cooling and air-cooling . . . . .	1	
	§ 3. Apertures for the projection room windows . . . . .	1	
X	List of spares and tools . . . . .		AA.K
XI	Suggestions for stocking spares . . . . .		AA.L
	§ 1. For the projector . . . . .	1	
	§ 2. For the pedestal and mounting table . . . . .	2	
XII	Catalogue numbers of the principal parts . . . . .		AA.M
	§ 1. Parts for FP 5 and FP 6 projectors . . . . .	1	
	§ 2. Parts for FP 7 projector . . . . .	2	
	§ 3. Parts for the driving mechanism of FP 5, FP 6 and FP 7 projectors . . . . .	3	
	§ 4. Parts of the flange motor and the pulley bearing plate of FP 5, FP 6 and FP 7 projectors . . . . .	3	
	§ 5. Parts of the pad rollers of FP 5, FP 6 and FP 7 projectors . . . . .	4	
	§ 6. Parts of the spool boxes and the safety fire-traps of FP 5, FP 6 and FP 7 projectors . . . . .	4	



**AA.A-1**

1-11-47

## I GENERAL DESCRIPTION

(Figs. 1 and 2)

Although the FP 5, FP 6 and FP 7 projectors differ greatly in construction, the instructions for operation and maintenance are essentially the same.

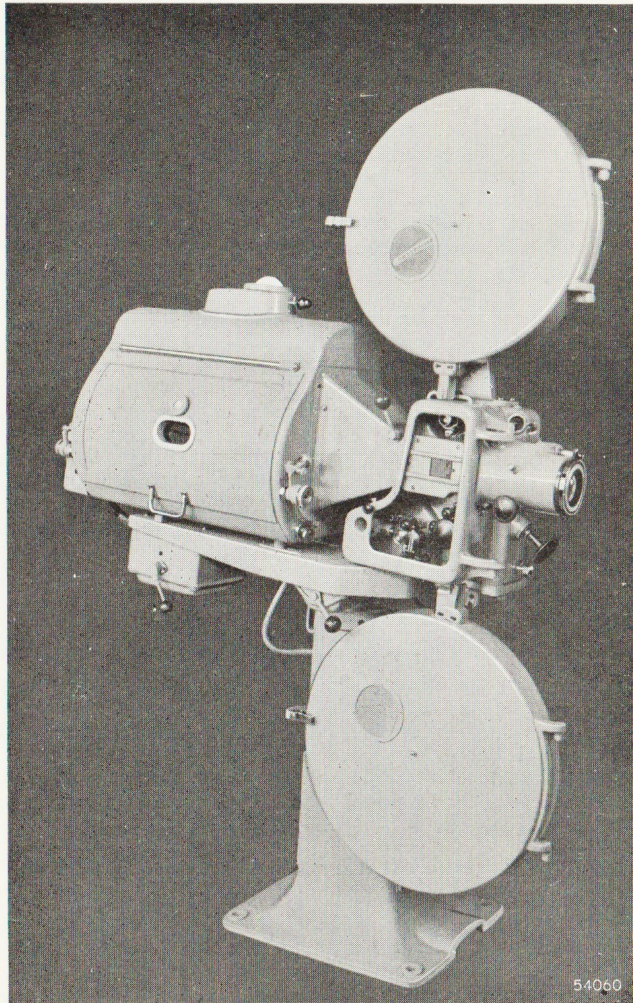
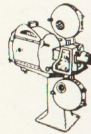
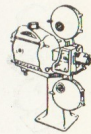

Fig. 1

FP 7 (fig. 1) is the ideal projector for very large cinemas but is also suitable for smaller auditoriums. It is provided with a built-in sound-head. The film path is enclosed by a



FP 5-6-7



FP 5-6-7

**AA.A-2**

1-11-47

hinged door with a glass window. Provision has been made for both water and air cooling; moreover it possesses manual loop correctors with which it is possible, even during operation, to regulate the length of the upper and the lower film loops.

The projector also incorporates an automatic film-rupture device which automatically closes a light shutter, switches off the motor and cuts off the electric supply to the exciter lamp in the event of the film stopping in front of the mask during operation.

The lens holder is suitable for lenses having a diameter up to 104 mm. The built-in sound-head is of the same construction as type 3837. The sound drum with flywheel ensures absolutely constant speed of the film on the spot where the sound track is scanned. A pressure roller, which, like the sound drum, has been mounted in high-precision ball bearings, presses the film on to the sound drum, so that the film reaches the required speed in about 3 seconds after starting.

The sound-scanning system has been so designed that by changing only two parts the sound-head is made suitable for reproducing "dual-track" sound films used in push-pull and stereophonic recordings.

For further particulars see the instructions for use for type 3837 sound-head (sheets AB).

The FP 6 (fig. 2) is of simpler design than the FP 7. This projector has no built-in sound-head but is normally supplied with type 3837 sound-head; it can, however, also be used in combination with other sound-heads.

The film-path is not enclosed.

The lens holder is suitable for lenses having a diameter up to 82.5 mm. The automatic film-rupture device can be supplied on request.

The FP 5 is a simplified model of the FP 6; it has no manual loop correctors and no water-cooling. The lens holder is suitable for lenses of a maximum diameter of 62.5 mm.

The principal features of the FP series may be summarized as follows:

1. **Central framing device.**

The Maltese cross rotates on its own spindle.

2. **In models FP 6 and FP 7 provision has been made for water-cooling.**

With water-cooling the edges of the film, which otherwise get very warm, remain perfectly cold, thus minimizing buckling and shrinkage of the film, which is otherwise apt to affect the quality of picture and sound and the life of the film.

Moreover the increase of temperature of the projector mechanism itself is only slight, even under continuous operation, and the oil retains its full lubricating properties.

3. **In the oil circuit there are two magnetic filters.**

One of these filters is combined with a fine-mesh gauze filter and is situated on the delivery side of the oil pump. The other filter is in the oil supply line to the intermittent unit; being placed behind the oil inspection glass it is easily accessible.

These filters extract from the oil the very small steel and iron particles that are apt to pass through the gauze filter. In this way wear and tear is minimized and acidification of the oil is reduced, so that the oil retains its full lubrication properties longer.

4. **Oil is circulated by a powerful high-pressure cog-wheel oil pump.**

The pump is always below the oil level, even when the projector is inclined at a great angle, thus ensuring reliability of operation.

**AA.A-3**

1.11.47

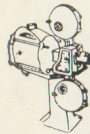

FP 5-6-7

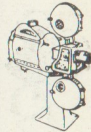

FP 5-6-7

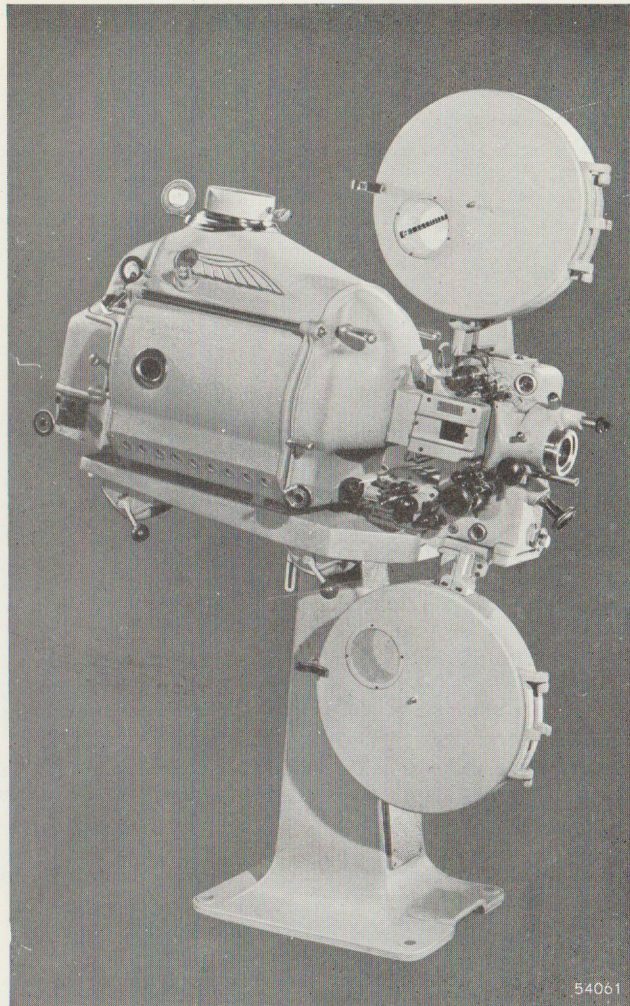
*Fig. 2***5. The lens holder forms one unit with the film door.**

The lens holder and the door are opened by means of the same push-button, which simplifies operation considerably.

**6. The film gate has been designed in such a way that a film joint is drawn between runners and film skates at minimum speed and also leaves at minimum speed.**

This reduces considerably the risk of film breakage and the joint passes almost noiselessly.

**AA.A-4**

1.11.47

**7. Central adjustment of the pressure of the film skates.**

The skates are controlled in the centre by a double spring which is adjustable by a single milled screw.

This simplifies operation and the pressure is distributed uniformly over the film, thus reducing wear of the machine and of the film to a minimum.

**8. Ventilating drum shutter.**

The drum shutter is provided with cooling fins so that the film is cooled in the film gate, even without the use of an air compressor. A stream of air is blown from the mask to the rear, ensuring that no carbon particles from the lamp house can reach the film. The air stream is not blown into the lamp house, but escapes above the light cone, so that the constancy of the arc is not affected.

**9. Possibility of connecting an air compressor.**

The projector has been provided with built-in air-cooling channels ending above the mask, before and behind the runner plate, thus ensuring proper cooling of the film from both sides exactly where it is struck by the beam of light.

**10. The whole mechanism is oil-tight, without any liquid sealing material.**

An oil guard on the inside of the back cover makes it impossible for any oil to leak through the joints. Therefore, it is not necessary to seal the joints and screw holes of the back cover; this facilitates service considerably.

**11. The intermittent sprocket has teeth with milled-in bases.**

Owing to this construction, the film lies perfectly flat on the surfaces between the teeth. As a result, the picture is steadier than when the bases are not milled in.

**12. The intermittent sprocket weighs only 16 grammes.**

Due to this low weight, the forces of acceleration remain small, thus reducing the wear and tear of the intermittent unit to a minimum.

**13. Safety clutch.**

Between the motor and the main shaft of the projector is a friction coupling which prevents damage to the gear wheels in case of a breakdown.

**14. Possibility of using a condenser lens.**

If the projection lens has a short focal distance the uniformity and brightness of the picture can be appreciably improved by using a condenser lens.

**15. The sound-head of the FP 7 projector can be adapted for "dual-track" reproduction.**

The "dual-track" system comprises push-pull as well as stereophonic recording, both of which improve the quality of reproduction. Since the sound-head can be easily converted for either of these systems it remains up-to-date even though recording technique may be progressing.

AA.B-1

1.11.47

## II HINTS ON INSTALLATION

The unpacking, setting up and testing of the equipment will usually be done by an expert. For this work the following hints are important.

### § 1. PREPARING THE PROJECTION ROOM

It is recommended to fit up the projection room completely before the apparatus is assembled and installed. The projection room windows with automatic fire shutters can be put in, in advance, with the aid of the particulars given on sheet AA.J-1. Under this heading is also a drawing of the water-pipes and air-ducts inside the projection room. The complete electric wiring can be laid on in advance too.

### § 2. UNPACKING

Care is to be taken when opening the cases; no hammer must be used, but a nail-puller. Do not try to pull the apparatus out of the cases before all the fixing material has been removed. Do not remove the oil-paper until all the wood-wool has been taken out. Special care should be taken not to leave any parts behind in the packing.

While the work of installation is going on, the apparatus should be covered with dust-sheets and kept dry. In the factory all bright parts have been safeguarded against rusting by greasing them with lanolin. This lanolin should not be removed before the equipment is ready for its first test.

On receipt of the equipment it is recommended to make sure that all the tools supplied with it and all the spare parts are present (see sheet AA.K-1).

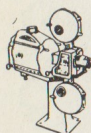

FP 5-6-7

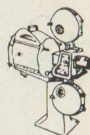

FP 5-6-7

AA.B-2

1.11.47

### § 3. ASSEMBLING THE EQUIPMENT

Fig. 1 shows the FP 7 projector on a de luxe pedestal with height adjustment type 8620; fig. 2 represents the FP 5 or FP 6 projector on the heavy pedestal type 8630.

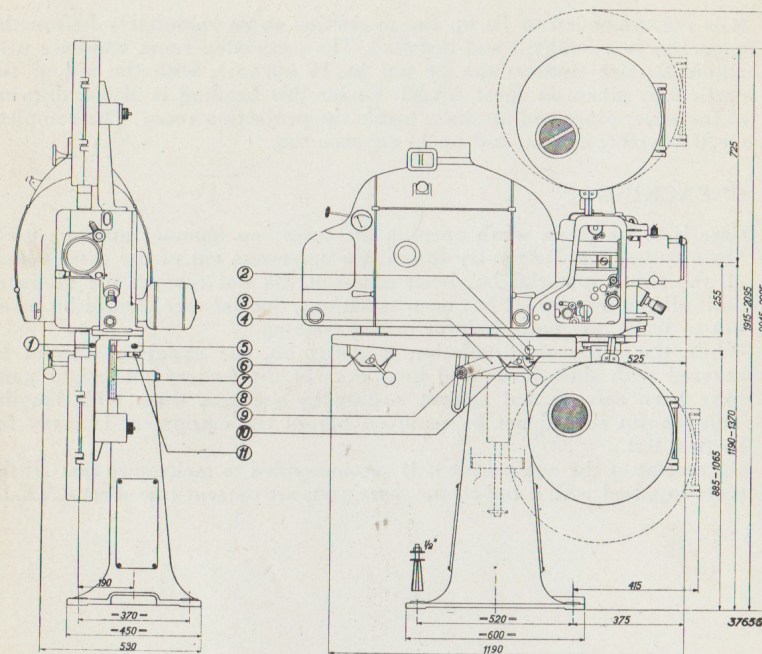

Fig. 1

#### 1. Positioning the pedestal

The pedestal must be placed in such a manner that its vertical side faces the operator. The height of the optical axis is 119 cm (47") for horizontal projection when the heavy pedestal is used; in the case of the de luxe pedestal, this height is adjustable between 119 and 137 cm (47" and 54").

For steeply inclining projectors wedges can be supplied with which the top spool box can be inclined backwards, so that the projector can be placed nearer the front wall of the projection room (see sheet AA.E-22).

#### 2. Fixing the mounting table

After setting up the mounting table, bolt "9" (spanner width 27 mm) must be well tightened. When subsequently adjusting to the correct projection angle the mounting table must be supported by an assistant before bolt "9" is loosened. After fixing the mounting table, pivot-spindle "2" is fixed with screws "3" and "11". Screws "1" and "5" with which this pivot-spindle is fixed in the pedestal (or, in the case of the pedestal with adjustable height, in yoke "4") are not tightened until the whole apparatus has been finally adjusted.

AA.B-3

1.11.47

### 3. Aligning the projector and the sound-head

Projector and sound-head can be aligned with each other by means of a steel ruler. A special aligning tool may also be used for the purpose which can be supplied to order under code number 22 467 36. This tool is placed on the sound-head in the manner shown in fig. 3; first the lower guide roller must be removed from its spindle. Then the sound-head and the projector are positioned so that the aligning tool is contiguous to the whole side of the bottom sprocket.

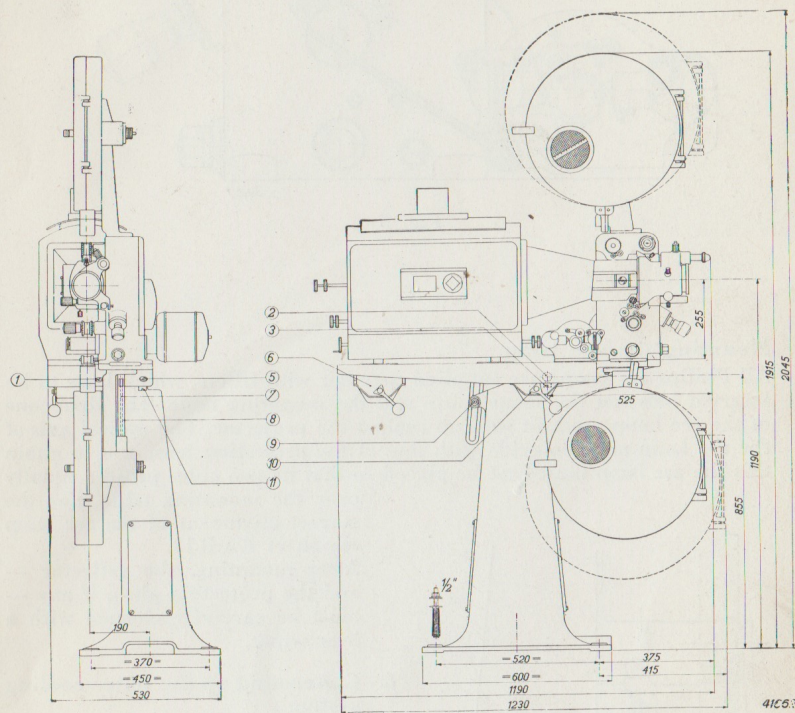
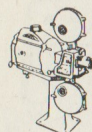

Fig. 2

### 4. Aligning the spool boxes (figs. 1 and 2)

The ends of coupling shaft "7" are well greased with vaseline or cardan grease and the shaft is put in place together with the bottom spool box. The rectangular holes in guard tube "8" facilitate the positioning of the coupling shaft underneath the projector. The spool boxes are aligned with a steel ruler. A special aligning tool may be ordered under code number 22 467 35 (fig. 4). Before aligning, the door of the spool box is opened, and also the safety fire-trap, and the long leg of the aligning tool is placed against the inside of the front runner of the safety fire-trap; the short leg must then be contiguous to the sprocket.



FP 5-6-7

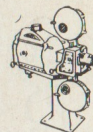

FP 5-6-7

AA.B-4

1.11.47

After mounting and aligning the bottom spool box it is necessary to check whether the coupling shaft can be easily moved up and down in all positions. Friction causes irregular running of the projector.

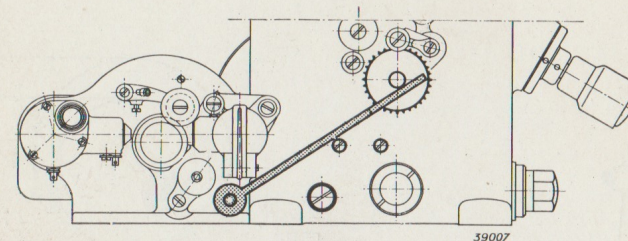

Fig. 3

### 5. Mounting the arc lamp

All Philips arc lamps are supplied together with fillers, which have to be inserted between the lamp house and the mounting table. The light-cone of the arc lamp must fit well up against the projector. The optical axis of the arc lamp must coincide with that of the projection lens, and to attain this the arc lamp must first be placed so that its two sides project equally over the mounting table. For the correct alignment of the arc lamp see sheet AA.B-12.

After mounting, the reflector — and the protecting glass, if any — must be carefully cleaned with a lens wiper.

### 6. Connecting up the water-cooling system

For connecting up the water-cooling system reference is made to sheet AA.E-18.

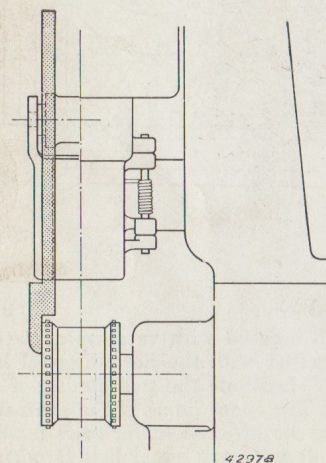
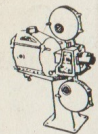
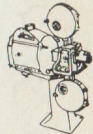

Fig. 4



FP 5-6-7



FP 5-6-7

§ 4 ELECTRICAL CONNECTIONS

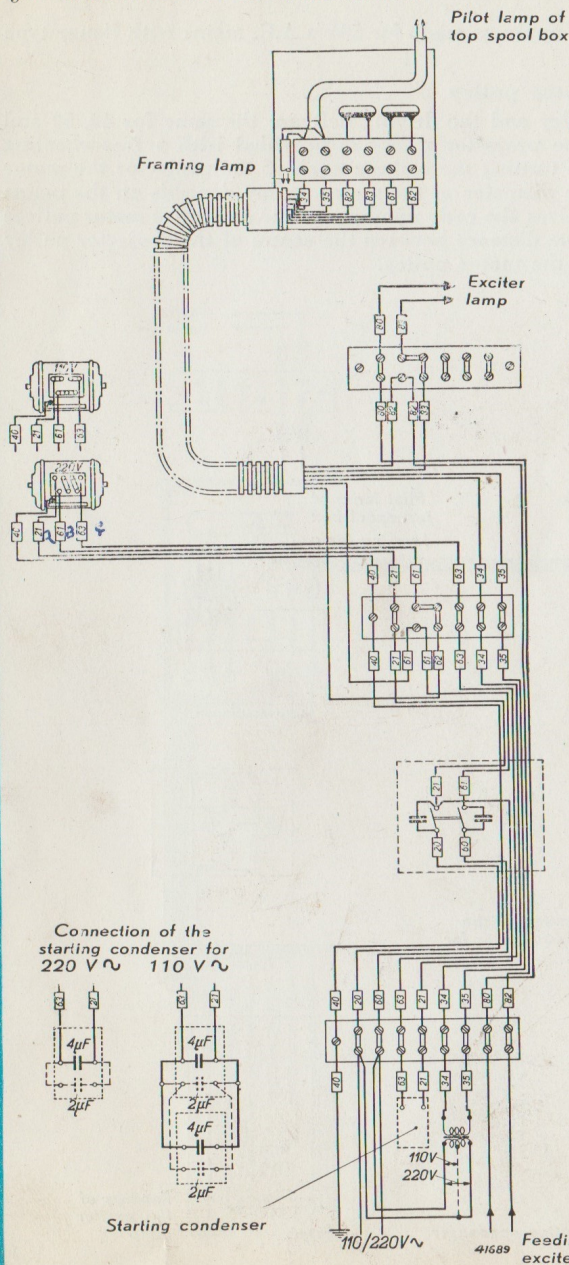

Fig. 5

1. A.C. mains

Fig. 5 shows the A.C. mains wiring required for a machine with automatic film-rupture device, while fig. 6 shows that for a projector without such a device.

a. 50-c/s A.C. mains with flange motor

Normally, the equipment as supplied is adjusted for 220 volts, but the whole apparatus can be readjusted on the spot to work on 110 volts. In the latter case the **motor windings** have to be connected in parallel instead of in series, while the **transformer** for the pilot lamps has to be re-soldered. A second **starting condenser** has then to be connected in parallel with the one supplied. This second condenser (to be ordered under code number 49 176 16) is fixed next to the first one, under the same bracket. Every starting condenser consists of two parts: one of 4 microfarads, which is used in normal circumstances, and one of 2 microfarads, which can be connected in parallel with the first part if a shorter starting time is desired.

b. 40, 50 and 60-cycle mains with pulley-motor

1. Mains voltage

The same remarks apply as made for 50-c/s A.C. mains with flange type motor.

2. Selecting the motor pulley

The projector pulley and the driving belt are the same for 40, 50 and 60-cycle mains. The projector pulley is provided with a free-wheeling device; thus when turning the inching knob of the projector the motor does not turn. The diameter of the motor pulley depends on the mains frequency. Fig. 7 gives the code numbers of the respective motor pulleys and the approximate distance between the centre of the projector pulley and the centre of the motor pulley.

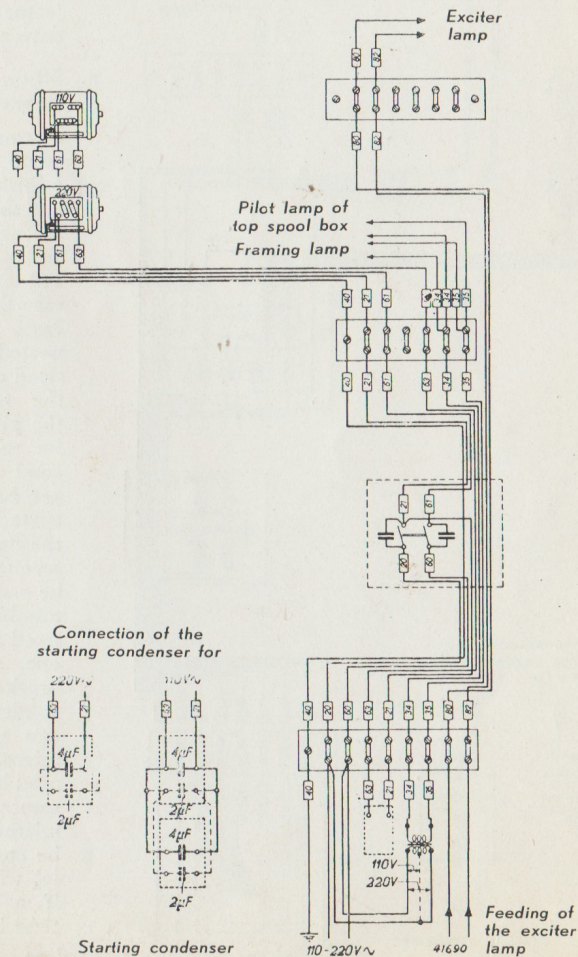
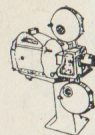

Fig. 6

AA.B-7

1.11.47



FP 5-6-7

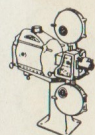

EP 5-6-7

AA.B-8

1.11.47

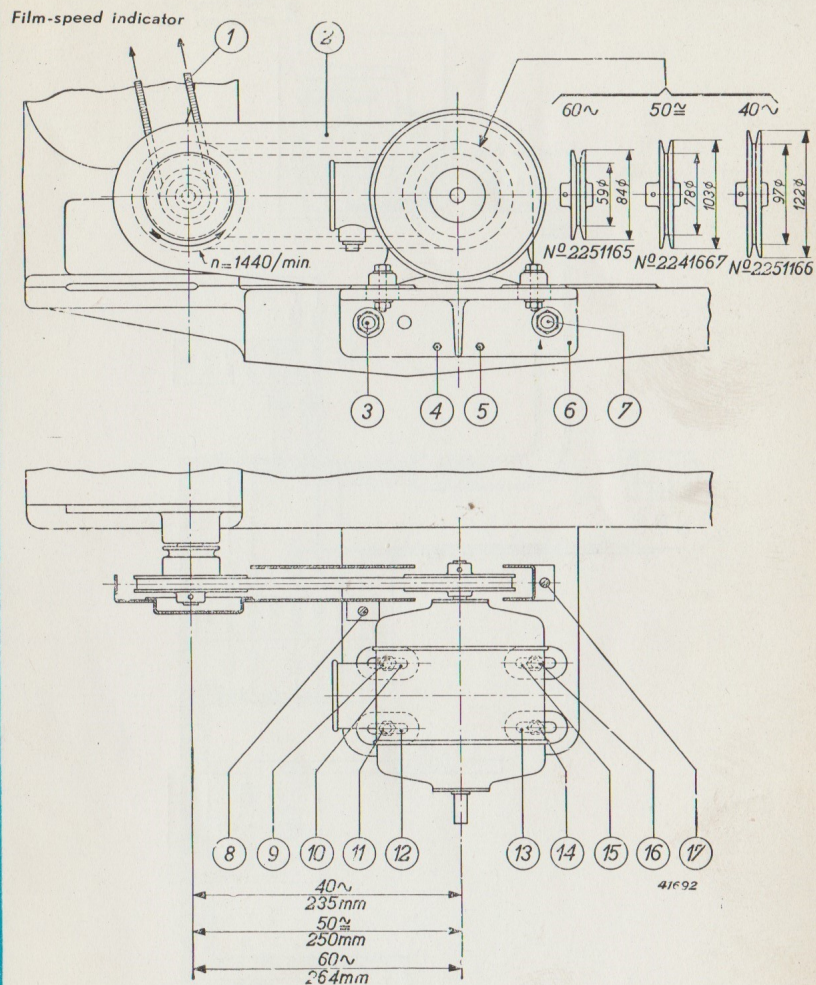

Fig. 7

3. Mounting the motor bracket and the motor (fig. 7)

Motor bracket "6" has to be fixed to the mounting table with the two bolts "3" and "7". Before tightening these bolts, the bracket must be positioned parallel with the mounting table by means of the bolts "4" and "5"; then bolts "3" and "7" are tightened. Next the motor is provisionally fixed on the bracket with the four bolts "9", "11", "14" and "16". The belt is then laid round the projector and motor pulleys and stretched taut by shifting the motor in the oblong holes "10", "12", "13" and "15" of the bracket. The motor is then aligned in such a way that the pulleys of motor and projector are in one line. Finally the guard "2" is fixed to the bracket with bolts "8" and "17".

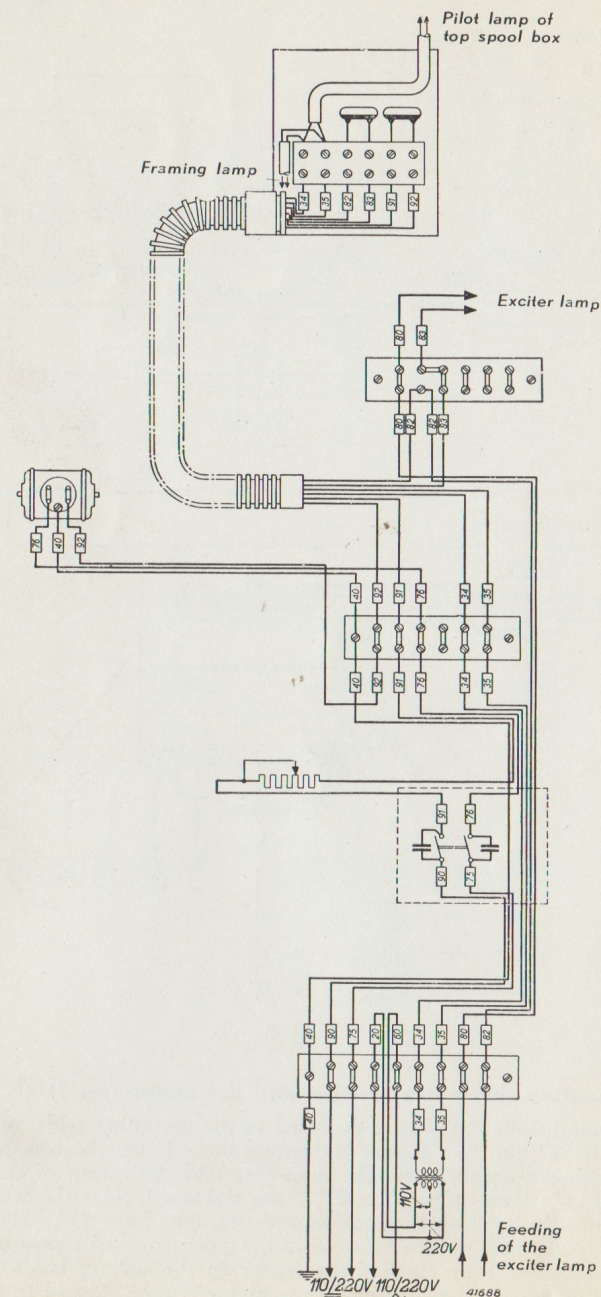
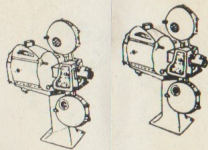

Fig. 8



FP 5-6-7

2. D.C. Mains

Fig. 8 shows the D.C. wiring for a projector with automatic film-rupture device, while fig. 9 represents that for a projector without such a device.

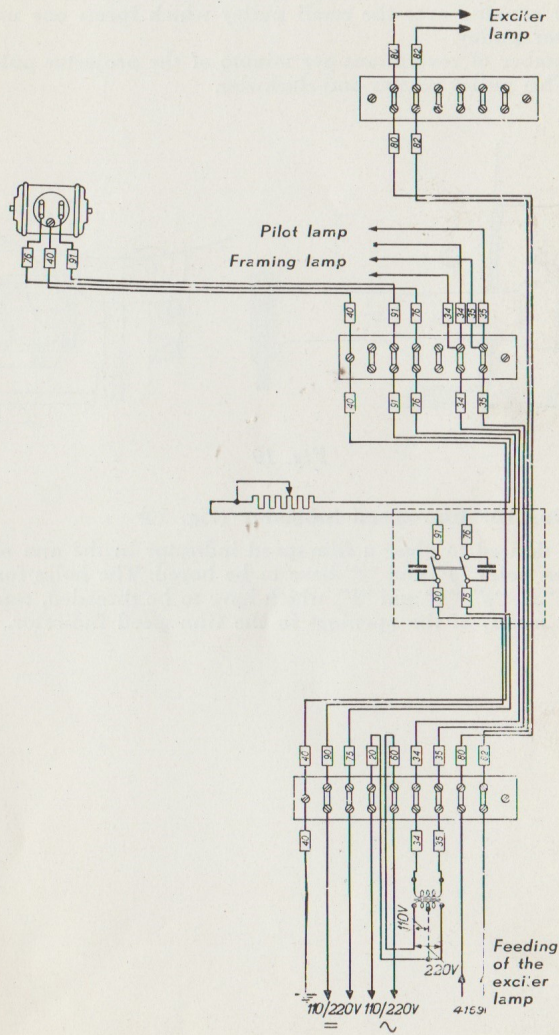

Fig. 9

a. Driving the projector

A D.C. pulley-motor is used in this case. The placing of this motor is similar to that of the 50-c/s A.C. pulley-motor.

b. Adjusting and checking the number of revolutions

Underneath the mounting table is a resistor for adjusting the speed. For checking the speed of the film, which can be accurately set at the required 24 pictures per second by means of the resistor, a film-speed indicator is used.

This film-speed indicator, type 8662/00, is driven by rubber belt "1" (fig. 7) running over the small pulley which forms one unit with the projector pulley.

The number of revolutions per minute of the projector pulley must be 1440. This pulley rotates anti-clockwise.

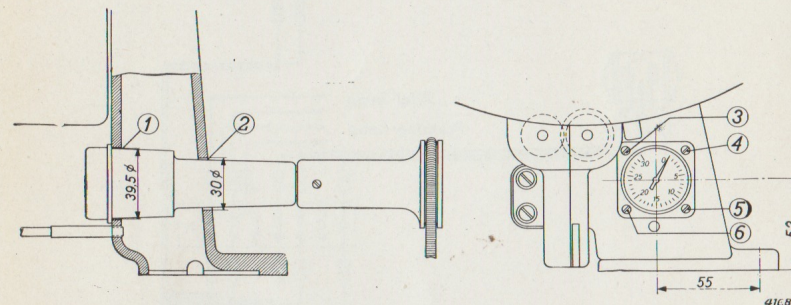

Fig. 10

c. Mounting the film-speed indicator (Fig. 10)

If it is desired to place a film-speed indicator in the arm of the spool-box, the holes "1" and "2" have to be bored. The holes for the 3 mm screws "3", "4", "5" and "6", which have to be threaded, can be marked out by means of the openings in the film-speed indicator.

## § 5. GETTING READY FOR OPERATION

## 1. Lamps and photo-electric cell

After pushing aside the red glass of the shutter cover the Philips framing lamp type 6914 can be put in the fitting. The pilot lamp illuminating the top spoolbox is of the same type and fits into a similar fitting as that for the framing lamp.

To place the Philips type 3874 (approx. 6 volts 1.48 amps) or type 7251 C (approx. 5 volts, 4.0 amps) exciter lamp — which of these has to be used depends on the type of current supply unit — in the sound-head of the FP 7 projector or in the type 3837 sound-head, the lid of the exciter lamp holder is opened.

This lamp is provided with a centering flange with notch, into which the stud on the holder engages, thereby focusing the lamp filament exactly. At the back of the sound-head is a cap under which the Philips type 3533 photo-cell is fitted; in case of "dual-track" reproduction two of these photo-cells are used.

## 2. Automatic film-rupture device type 8669

The exact position of the holder for the mercury switches of the automatic film-rupture device depends on the angle at which the projector is inclined. This holder must be adjusted in such a way that when in the position in which they have to make contact the mercury tubes lie horizontally (see sheet AA.E-20).

## 3. Lubrication

- Hook up the magnet behind the oil inspection glass on the top right-hand side of the projector.
- Fill the projector with oil as indicated on sheets AA.D.

## 4. The lenses

- For determining the focal lengths of the film projection lens and the slide projection lens see chapter "General".
- For fitting in the film projection lens see sheet AA.E-2.

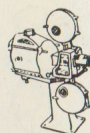

FP 5-6-7

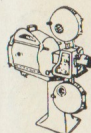

FP 5-6-7

## § 6. ADJUSTING THE APPARATUS

## 1. Adjusting the projector while running without film

When projecting without film the mask has to be sharply focused on the screen; at the same time the automatic lubrication is to be checked behind the oil inspection glass in the top right-hand corner of the projector. While projecting, the apparatus has to be adjusted in such a way that the light beam passes through the centre of the projection room window and the image of the mask is thrown symmetrically onto the screen; if the picture is too large or too small a projection lens with a longer or shorter focal length has to be chosen.

## 2. Adjusting the arc lamp

The projector and arc lamp are started up without film and without projection lens. The crater then appears on the screen as a round black spot, which is centred on the screen by means of the reflector. The lens is then inserted in the holder and the mask focused. The picture field should then be symmetrically illuminated, and if this is not the case the arc lamp must be moved laterally and the aforementioned adjustments repeated.

## § 7. TRYING OUT THE PROJECTOR IN OPERATION WITH A FILM LOOP

Clean all greased parts with pure benzine and a clean cloth.

Black film loops of abt. 7' (2.2 m) length for trying out the FP 5, FP 6 and FP 7 projectors can be supplied under code number 22 463 87.

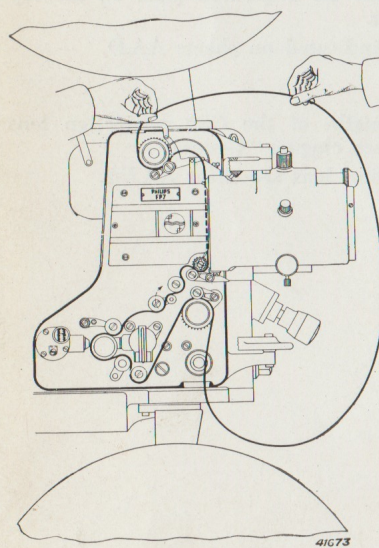

Fig. 11

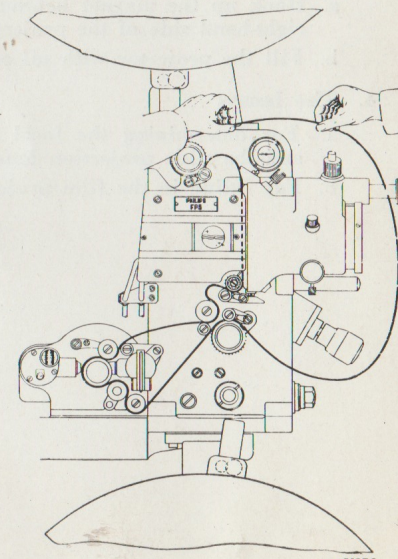

Fig. 12

## a. Trying out the FP 7 projector

Remove the fire-traps of the spool boxes and thread a new 7' film loop in the projector in the manner shown in fig. 11. Let the loop run



**AA.B-13**

L.11.47

through the projector about 50 times and then examine the film; from the nature of any damage to the film it is possible to determine the cause.

**b. Trying out the FP 5 and FP 6 projectors with type 3837 sound-head**

Thread a new 7' loop in the projector and sound-head as shown in fig. 12 and let it run through about 50 times. Examine the film for any damage.

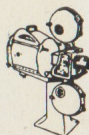

FP 5-6-7

**§ 8. TRYING OUT THE PROJECTOR IN OPERATION WITH A FILM**

- a. Thread up an old test film (see sheet AA.C-1). While the film is running adjust the pressure of the skates and the frictions of the top and bottom spool boxes (see sheets AA.E-5 and 23). Check the alignment of the spool boxes and sound-head in respect to the projector. The film should run smoothly over the sprockets and through the safety fire-traps without damage.
- b. Project a good picture-test film and see that the text is perfectly horizontal. If necessary adjust the apparatus, for instance by inserting one or more metal plates underneath the pedestal. After the wedge bolts have been finally tightened up another test run is to be made.
- c. For testing the speed of the machine a tachometer can be placed in the centering hole of the top sprocket spindle, which for 24 pictures per second should make  $180 \pm 2$  revolutions per minute. Check whether the mains frequency is the right one.

**III OPERATION**

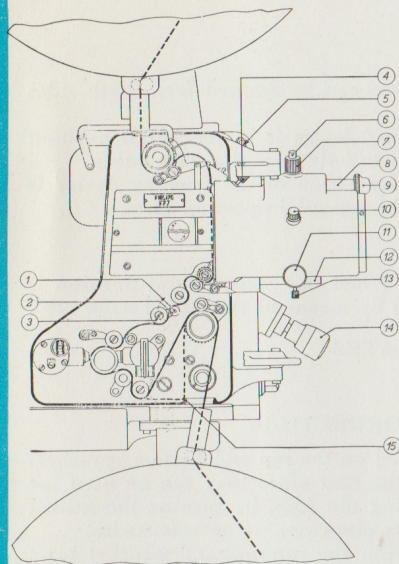

Fig. 1

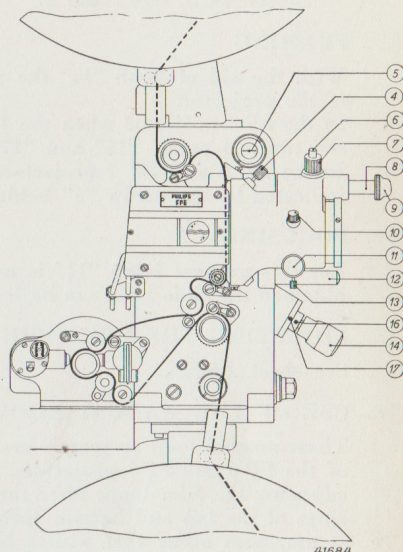

Fig. 2

**§ 1. THREADING THE FILM**

The film path of the FP 7 projector is shown in fig. 1 and that of the FP 5 and FP 6 projectors with type 3837 sound-head in fig. 2.

The rollers of the safety fire-trap are positioned for a clockwise rotation of the top spool. If it is desired to have this spool rotate anti-clockwise the rollers have to be interchanged (see sheet AA.E-25).

Upon pressing the button "6" the lens holder with door slides to the right along the two guide rods "8" and "12", so that the film can be threaded. By means of button "7" the lens holder is returned and at the same time the pad roller of the intermittent sprocket is shut automatically.

With the FP 7 projector the right size of the bottom film loop is obtained by stretching the film between the intermittent sprocket and the bottom sprocket and pressing it against the stud "15" (see fig. 1); when the projector is started up a loop of the right size is then automatically obtained.

**§ 2. SWITCHING ON**

**1. Projector**

When connected to **A.C. mains** the motor is switched on with switch "10" (see sheets AA.B, figs 1 and 2). The same switch is used also for **D.C. mains**, but when switching on for the first time the whole variable resistor underneath the inclinable mounting table has to be connected in series; after switching on the speed is adjusted to 24 pictures per second with the aid of that resistor and the film-speed indicator. After that, the resistor is only used to adjust any small variations in speed due, for instance, to considerable fluctuations in the mains voltage.

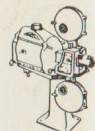

FP 5-6-7

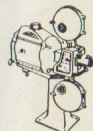

FP 5-6-7

**2. Arc lamp**

The arc lamp supply is switched on by means of switch "6" (see sheets AA.B, figs 1 and 2).

**§ 3. FRAMING**

With the aid of knob "14" the picture can be framed from both sides of the projector.

In the FP 5 projector when the framing device is in its central position the two red points "16" and "17" lie exactly opposite each other.

In the FP 6 and FP 7 projectors the position of the framing device is indicated by the arrow "5" behind the top oil inspection glass.

**§ 4. FOCUSING**

For this purpose knob "11" is used. When the correct focal position is obtained the slide bush can be locked by means of the milled screw "10".

**§ 5. ADJUSTING THE PRESSURE SKATES**

See sheet AA.E-5.

**§ 6. USE OF THE MANUAL LOOP CORRECTORS**

These manual loop correctors are fitted on the top and bottom sprockets of the FP 6 and FP 7 projectors. In the first place they can be used for adjusting the film loops after threading the film, by turning the milled rings of the top and bottom sprockets clockwise or anti-clockwise.

It may also occur that with a bad film the intermittent sprocket tears through the perforation until the bottom sprocket draws the film past the mask again. In that event the bottom film loop becomes too small and the top one too large, and if the sprockets were not provided with loop correctors the apparatus would have to be switched off for re-adjusting the film loops to the right length. With manual loop correctors, however, it is only necessary to brake the milled rings until the loops have assumed the right size again.



**AA.D-1**

1.11.47

## IV MAINTENANCE

1. All the instructions necessary for maintenance are to be found in the illustrations 1 and 2 supplied with every FP 7 installation and in illustrations 3 and 4 supplied with the FP 5 and FP 6 installations.
2. Proper observance of these instructions is most essential for the durability of the projector.
3. The lubricating oil must always be kept in closed tins. The oil funnel must be clean.
4. Use Philips oil exclusively.

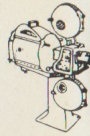

FP 5-6-7

# PHILIPS PROJECTOR FP 7 INSTRUCTIONS FOR MAINTENANCE

## CLEANING

## LUBRICATION

PART	TO BE CLEANED
Top spool box . . . . .	daily
Fire-trap and rollers . . . . .	daily
Magnetic filter . . . . .	every 3 months
Top sprocket and pad roller . . . . .	daily
Runner plate and skates . . . . .	daily
Projection lens . . . . .	as needed (with lens wiper)
Intermittent sprocket and pad roller . . . . .	daily
Guide rollers (3 on projector and 2 on soundhead) . . . . .	daily
Pressure roller . . . . .	daily
Optical system . . . . .	as needed (with soft brush; do not dismantle)
Sound drum and exciter lamp holder . . . . .	daily
Bottom sprocket and pad roller . . . . .	daily
Fire-trap and rollers . . . . .	daily
Bottom spool box . . . . .	daily

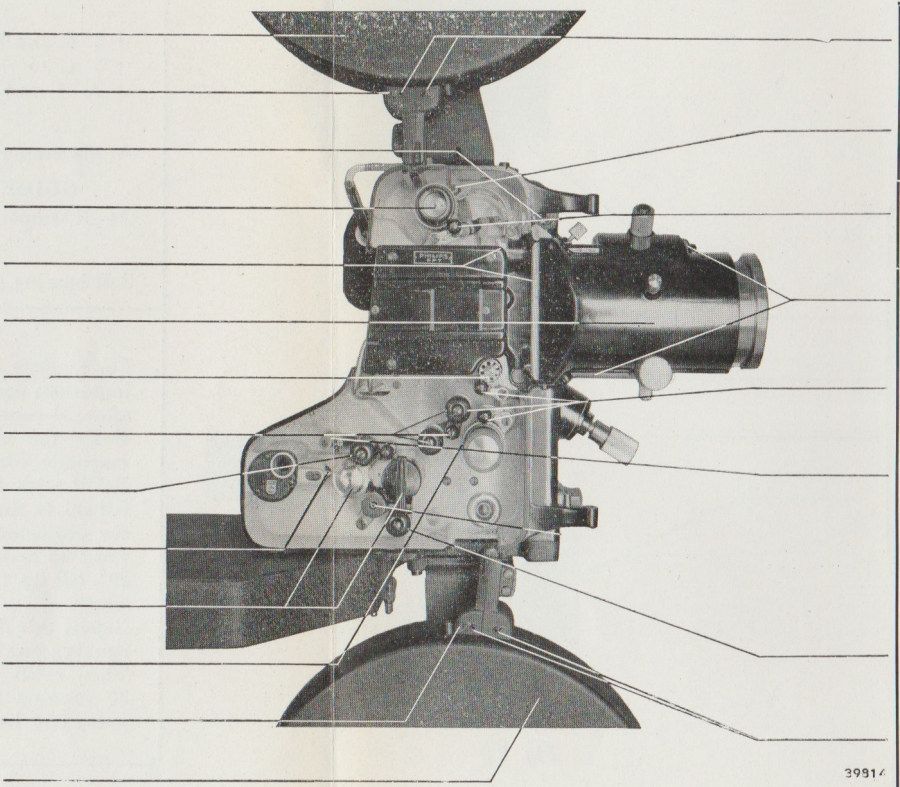
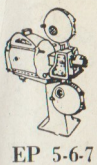

Fig. 1

PART	TO BE LUBRICATED	OIL
Fire-trap rollers. . . . .	weekly (through the hollow spindles)	spindle oil
6 rotating points of aut. film-rupture device . . . . .	monthly	spindle oil
Pad rollers . . . . .	weekly (through the hollow spindles after loosening the ornamental screw)	spindle oil
Guide rods of lens holder . . . . .	monthly	cardan oil
2 Pad rollers . . . . .	weekly (through the hollow spindles after loosening the ornamental screw)	spindle oil
3 Guide rollers of projector . . . . .	weekly (remove screw and take off roller)	spindle oil
Rotating point of pressure roller . . . . .	monthly	cardan oil
2 Guide rollers of soundhead . . . . .	weekly (remove ornamental screw and take off roller)	spindle oil
Fire-trap rollers . . . . .	weekly (through the hollow spindles)	spindle oil



**AA.D-3**

L.11.47

# PHILIPS PROJECTOR FP 7 INSTRUCTIONS FOR MAINTENANCE

PART	TO BE CLEANED
Top friction felt disc . . . . .	every 3 months (saturate felt in cardan oil)
Motor . . . . .	every 3 months (exterior)
Gauze and magnetic filter . . . . .	every 3 months
Bottom friction felt disc . . . . .	every 3 months (saturate felt in cardan oil)

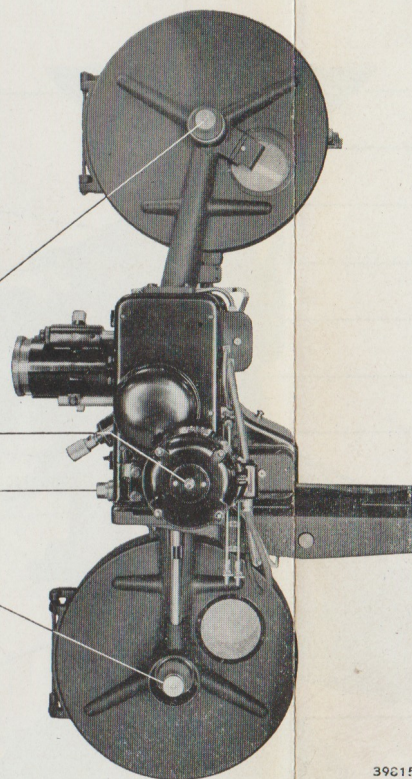

Fig. 2

39215

### OILS TO BE USED (exclusively Philips Oils) PROJECTOR

- + 5° C and lower : thin oil No. 3671
- + 5° C to + 25° C: medium oil No. 3672
- + 25° C and higher: heavy oil No. 3673

### ALL ROLLERS

At all temperatures: thin oil No. 3671

### GUIDE RODS AND FELT FRICTION DISCS

At all temperatures: cardan oil No. 8657

### BALL BEARINGS

Ball bearing grease No. 3685

### REFILLING WITH FRESH OIL

For a newly installed projector and also after replacement of important parts such as the intermittent unit and gear wheels, after 20 running hours:

Drain the oil and clear out the gauze filter and the two magnetic filters.

Refill with fresh oil **while the projector is running**; fill up to the top of the red circle on the oil level gauge if the projector is inclined upward, and if it is inclined downward up to an angle of 20°; if inclined downward more than 20° fill up to the bottom of the red circle on the oil level gauge.

Repeat this draining and refilling after the projector has been running one day.

Then refill the oil in the manner described above after 30 running hours, then after 50 and after 150 and finally every 250 hours.

# PHILIPS PROJECTOR FP 5 OR FP 6 WITH SOUND-HEAD TYPE 3837 INSTRUCTIONS FOR MAINTENANCE

## CLEANING

PART	TO BE CLEANED
Top spool box . . . . .	daily
Fire-trap and rollers . . . . .	daily
Magnetic filter . . . . .	every 3 months
Top sprocket and pad roller . . . . .	daily
Runner plate and skates . . . . .	daily
Projection lens . . . . .	as needed (with lens wiper)
Intermittent sprocket and pad roller . . . . .	daily
Guide rollers (2 on projector and 2 on sound-head) . . . . .	daily
Pressure roller . . . . .	daily
Optical system . . . . .	as needed (with soft brush; do not dismantle)
Sound drum and exciter lamp holder . . . . .	daily
Bottom sprocket and pad roller . . . . .	daily
Fire-trap and rollers . . . . .	daily
Bottom spool box . . . . .	daily

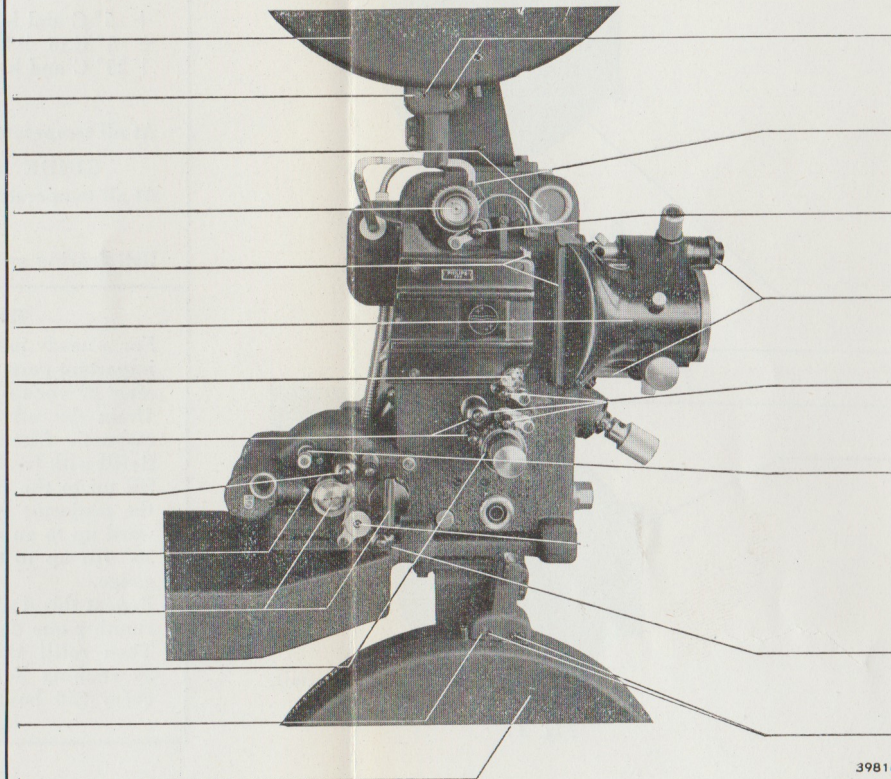
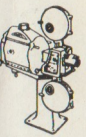

Fig. 3

## LUBRICATION

PART	TO BE LUBRICATED	Oil
Fire-trap rollers. . . . .	weekly (through the hollow spindles)	spindle oil
6 rotating points of aut. film-rupture device . . . . .	monthly	spindle oil
Pad rollers . . . . .	weekly (through the hollow spindles after loosening the ornamental screw)	spindle oil
Guide rods of lens holder . . . . .	monthly	cardan oil
2 Pad rollers . . . . .	weekly (through the hollow spindles after removing the ornamental screw)	spindle oil
2 Guide rollers (on the projector) . . . . .	weekly (remove screw and take off roller)	spindle oil
Rotating point of pressure roller . . . . .	monthly	cardan oil
2 Guide rollers of sound-head . . . . .	weekly (remove ornamental screw and take off roller)	spindle oil
Fire-trap rollers . . . . .	weekly (through the hollow spindles)	spindle oil



EP 5-6-7

**AA.D-5**  
1.11.47

# PHILIPS PROJECTOR FP 5 OR FP 6 WITH SOUND-HEAD TYPE 3837 INSTRUCTIONS FOR MAINTENANCE

PART	TO BE CLEANED
Top friction felt disc . . . . .	every 3 months (saturate felt in cardan oil)
Motor . . . . .	every 3 months (exterior)
Gauze and magnetic filter . . . . .	every 3 months
Bottom friction felt disc . . . . .	every 3 months (saturate felt in cardan oil)

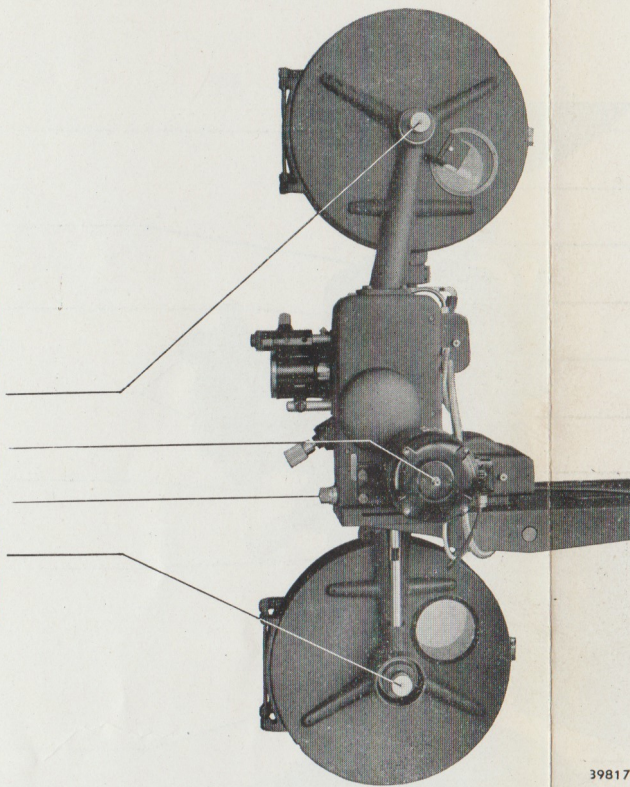

Fig. 4

39817

**OILS TO BE USED**  
(exclusively Philips Oils)  
**PROJECTOR**

+ 5° C and lower : thin oil No. 3671  
+ 5° C to + 25° C : medium oil No. 3672  
+ 25° C and higher : heavy oil No. 3673

**ALL ROLLERS**  
At all temperatures: thin oil No. 3671

**GUIDE RODS AND FELT FRICTION DISCS**  
At all temperatures: cardan oil No. 8657

**BALL BEARINGS**  
Ball bearing grease No. 3685

---

**REFILLING WITH FRESH OIL**

For a newly installed projector and also after replacement of important parts such as the intermittent unit and gear wheels, after 20 running hours:  
Drain the oil and clear out the gauze filter and the two magnetic filters.  
Refill with fresh oil **while the projector is running**; fill up to the top of the red circle on the oil level gauge if the projector is inclined upward, and if it is inclined downward up to an angle of 20°; if inclined downward more than 20° fill up to the bottom of the red circle on the oil level gauge.  
Repeat this draining and refilling after the projector has been running one day.  
Then refill the oil in the manner described above after 30 running hours, then after 50 and after 150 and finally every 250 hours.

## V DESCRIPTION OF THE PARTS AND THEIR MAINTENANCE

### § 1. OIL CIRCULATION IN THE PROJECTOR (Fig. 1)

The lubricating system of the driving mechanism contains a high-pressure cog-wheel oil pump.

The cog-wheels and the suction opening of the pump are always below the oil level, so that the pump can never "pump empty" or fail to act after not being used for a long time. The oil is pumped in to the delivery pipe via a composite gauze and magnetic filter.

The main delivery outlet is in the top right-hand corner of the projector housing behind the oil inspection glass; from there the oil flows via a second magnetic filter through a funnel directly to the intermittent unit, which thus receives oil that has been filtered three times.

The oil delivery pipe has also branches leading to the other points to be lubricated.

After draining the oil the combined gauze and magnetic filter can be pulled out of the drain opening. The magnetic oil filter behind the oil inspection glass can be removed after unscrewing this glass.

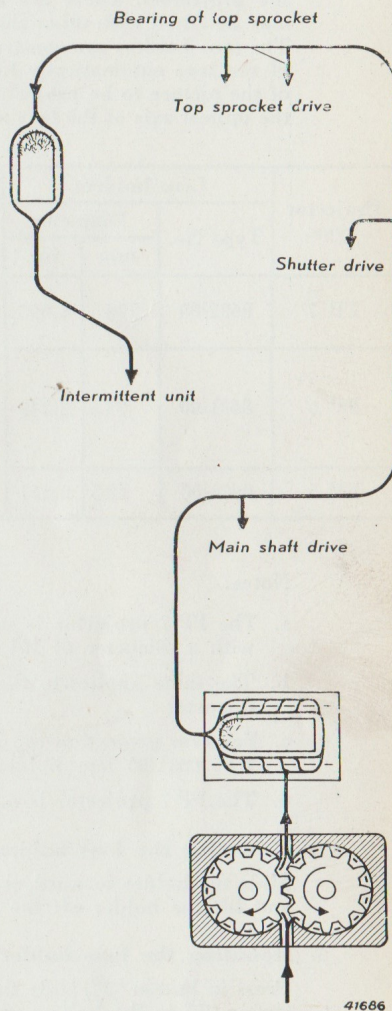
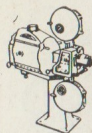
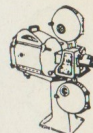

Fig. 1

Never let the projector run without filters!



FP 5-6-7



FP 5-6-7

### § 2. LENS HOLDERS, ADAPTERS AND LENSES (Fig. 2)

#### 1. Description

The table below gives a list of the lens holders normally fitted on the projectors. These are all interchangeable, so that a projector may be fitted with other than the normal lens holder.

The lens holders are constructed in such a way that the optical axis of the lens automatically falls exactly in line with the optical axis of the picture to be projected; it was therefore unnecessary to make the optical axis of the lens adjustable.

Projector type	Lens holders			Adapters		
	Type No.	Diameter		Type No.	Diameter	
		mm	in.		mm	in.
FP 7	8682/00	104	4.095	8685/00	104 /62.5	4.095/2.461
				8686/00	104 /82.5	4.095/3.248
FP 6	8681/00	82.5	3.248	8683/00	82.5/62.5	3.248/2.461
				8696/00	82.5/42.5	3.248/1.673
				8684/00	82.5/42.5	3.248/1.673 (eccentric)
FP 5	8680/00	62.5	2.461	8695/00	62.5/42.5	2.461/1.673

#### Notes:

- The FP 7 projector is normally fitted with a holder for lenses with a diameter of 104 mm.
- The same applies to the FP 6 projector for lenses of 82.5 mm diameter.
- For rear projection the FP 5 and FP 6 projectors are used with type 8681/00 lens holder with eccentric adapter type 8684/00.
- The FP 7 projector is not suitable for rear projection.

#### 2. Removing the lens holder

Slide the holder forward, remove screw "6" and ornamental nut "8" and lift the holder off the guide rods.

#### 3. Mounting the lens holder

Press in button "3", slide the holder onto the guide rods, press back spring "5" in the hollow rod "7", past screw "6" (for instance with

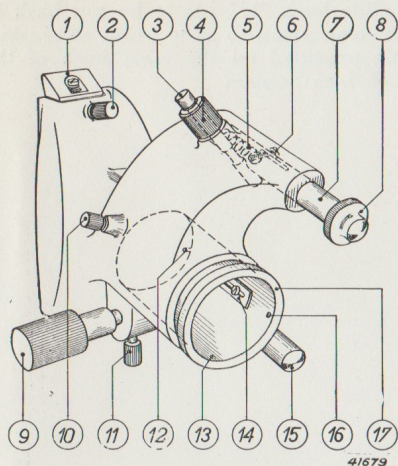

Fig. 2

41679

a screwdriver), tighten up screw "6" and fix nut "8".

When a projector is inclined forward at a large angle it may happen that upon being opened, for instance for threading in a film, the lens holder will shoot forward too quickly and strike up hard against nut "8", which may throw the lens out of adjustment. In that case it is advisable to shorten the pressure spring "6" by cutting off one or more windings.

#### 4. Lubricating the lens holder

The guide rods "7" and "15", slide bush "17" and rack and pinion for focusing should be lubricated with cardan oil.

#### 5. Mounting the lens in the slide bush of the holder

In the type 8680/00 and type 8681/00 lens holders all normal lenses with a focal length of 75 to 120 mm are slipped in against the stop "12" and held in position with the adjustable plate "14". Lenses with a focus of 120 mm and longer are fixed in the bush "17" with the screws "13" and "16".

#### 6. Mounting the lens in the adapter

In the type 8683/00, type 8685/00 and type 8695/00 adapters lenses with a focus of 75 to 120 mm are inserted up against the stop and held by an adjustable plate. Lenses with a focus of 120 mm and longer are fixed in the adapter with screws; the same applies for all lenses to be fitted in adapters other than those enumerated above.

#### 7. Mounting the adapter in the slide bush of the lens holder

The adapters type 8684/00, type 8695/00 and type 8696/00 are placed in the bush "17" up against the stop "12" and held in position by the adjustable plate "14". Other adapters are fixed in the bush with the screws "13" and "16".

All adapters for type 8682/00 lens holders, as also the type 8684/00 eccentric adapters, have to be placed in a certain position. In the front rim of the adapter is a groove and on the inside is the word "TOP"; the adapter has to be mounted with these marks uppermost.

#### 8. Cleaning the lens

Unscrew the milled screw "11" and pull out adjusting knob "9"; remove the slide bush "17" with the lens and clean front and back of the lens with a clean lens wiper that is supplied.

The lens should only be cleaned when absolutely necessary, as in cleaning there is always the risk of the lens being scratched.

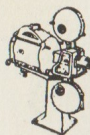

FP 5-6-7

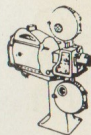

FP 5-6-7

After cleaning the lens the slide bush "17" has to be put back in the lens holder in exactly the same place, so as to avoid refocusing. This is facilitated by a scale provided on the slide bush of the type 8681/00 and type 8682/00 lens holders.

**AA.E-5**

1.11.47

### § 3. PRESSURE SKATES (in pairs, code number 22 741 17)

#### 1. Description

The skates are made of steel; they serve for the projection of old and new copies. A double spring presses them against the film in such a manner that the pressure is evenly distributed; this pressure can be adjusted with a single screw "2" (fig. 2).

#### 2. Operation

The pressure of the skates should be as light as possible in order to reduce the load on the film perforations and the intermittent unit and also to minimize wear of the teeth on the intermittent sprocket.

Correct adjustment of the pressure is obtained by first leaving the adjusting screw sufficiently loose so that in the test run the picture begins to dance, then slowly tighten the screw until the picture just becomes steady.

If the runner plate or the skates are replaced, and also when projecting colour films, which are thicker than black and white films, the pressure of the skates has to be re-adjusted.

#### 3. Maintenance

Once a day the skates should be taken out — by lifting the block "1" (fig. 2) — and thoroughly cleaned with an oiled cloth. After the skates have been put back check whether they move easily.

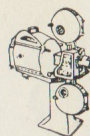

FP 5-6-7

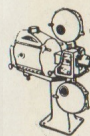

FP 5-6-7

**AA.E-6**

1.11.47

### § 4. STEEL RUNNER PLATE WITH LATERAL PRESSURE PIECE (code number 22 415 12)

#### 1. Description

The runner plate (fig. 3) is made of hard-wearing stamp steel and the lateral pressure piece "1" of hardened ball-bearing steel. The pressure piece can be fitted on either side of the runner plate. When the projectors are delivered this pressure piece is already adjusted to give a steady picture in the lateral direction.

The right position for the pressure piece is determined in the following manner.

Remove the pressure piece and start projecting a film. With a pencil press the film directly over the runner plate first to the left then to the right. The shifting of the picture on the screen shows on which side the space between film and edge of the runner plate is greater, and it is on that side that the pressure piece has to be fitted.

When removing and replacing the pressure piece make sure that the spring is not bent out of shape.

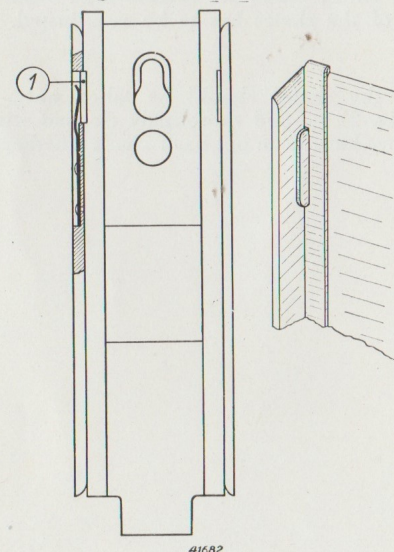

Fig. 3

If in the case of an installation of two or more projectors the pressure pieces on the different runner plates are not all on the same side, take care not to interchange the runner plates.

#### 2. Maintenance

The runner plate is easily taken out after sliding it upwards. If after a time the pressure piece shows a groove caused by wear it can be turned 180° around its longitudinal axis, thus doubling its life.

AA.E-7

1.11.47

It is of the utmost importance that the place where the pressure piece is fitted should be regularly cleaned, for instance with a toothbrush.

Accumulation of dirt seriously affects operation.

The runners of the plate are highly polished in the factory and must be wiped with an oiled rag every time another spool is put in.

Coked emulsion has to be carefully removed with a piece of wood and *never* with a metal object.

When projecting a new film, which often leaves a deposit, it is recommendable to use a runner plate covered with velvet.

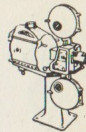

FP 5-6-7

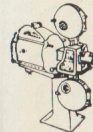

FP 5-6-7

AA.E-8

1.11.47

## § 5. VELVET-COVERED RUNNER PLATES

### 1. Description

These runner plates are for use when giving a first run of a new or almost new film. Compared with bare steel runners they have the advantage that no hard emulsion scales from the film can be deposited on the velvet.

Old films and films with torn edges and torn perforations must never be run on velvet-covered runners, because such films may catch in the velvet and cause film rupture.

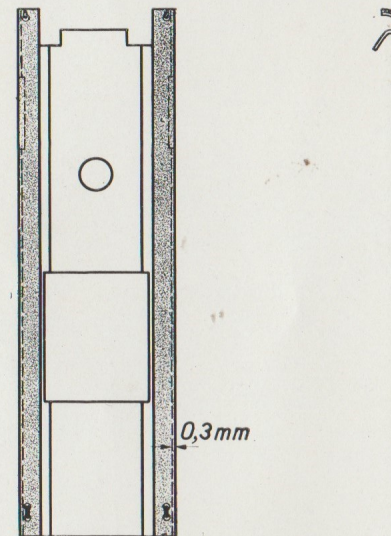

Fig. 4

Velvet-covered runner plates can be supplied in two kinds:

- Simple finish** (fig. 4, code number 22 415 46)  
This is normally supplied with the FP 5 and FP 6 projectors. It is laid over the ordinary steel runner plate. The velvet strips are glued on over their entire length and sewn at the ends with thread. If the strips have to be renewed see to it that the new ones extend 0.012" (0.3 mm) either side.
- De luxe finish** (fig. 5, code number 22 415 93)  
This is normally supplied with the FP 7 projector but can also be ordered for the FP 5 and FP 6 projectors. It replaces the normal runner plate and is therefore provided with a lateral pressure piece. Instead of being glued on, the velvet is knotted and consequently can easily be renewed. Furthermore this pre-

AA.E-9

1.11.47

cludes film damage from hard pieces of agglutinant. The velvet is fixed as follows:

After laying the velvet on the runners, press on the spring at "A" till it stays behind the lip.

Stretch and knot the velvet as tight as possible. Then press the spring at "B", when it will spring back and thus stretch the velvet tight over the runners.

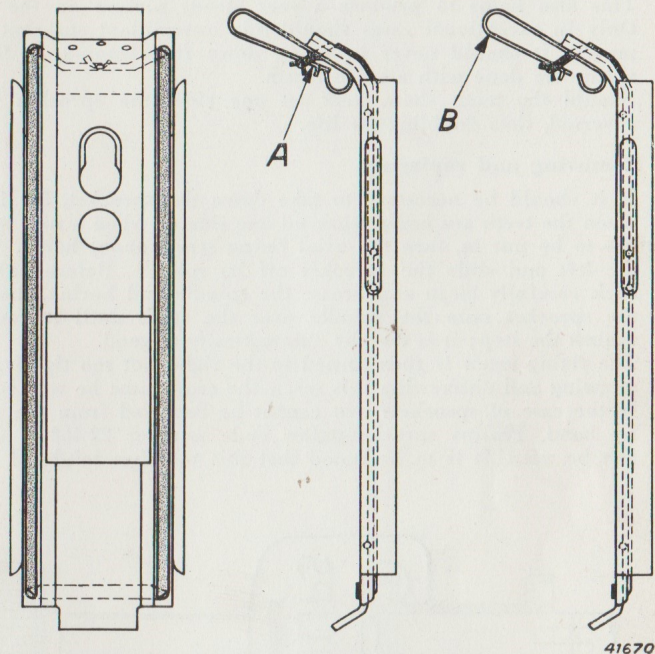

Fig. 5

## 2. Adjustment and maintenance

As the film is more subject to friction on velvet than it is on steel, and velvet-covered runners are thicker than steel ones, the pressure of the skates must be reduced when a steel runner plate is replaced by one covered with velvet.

The velvet must be brushed (a tooth brush is best) every time another film spool is threaded in. Always brush downwards only, in the direction the film runs.

The velvet must be renewed in good time! If it is allowed to wear too much the film may be damaged.

It is advisable to keep one or more spare velvet-covered runner plates in stock.

A spare strip of velvet 41" (105 cm) long (code number 06 602 69) is supplied with every projector; this is sufficient for re-covering two runner plates of code number 22 415 93 or four plates number 22 415 46.

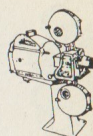

FP 5-6-7

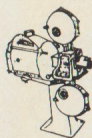

FP 5-6-7

AA.E-10

1.11.47

## § 6. INTERMITTENT SPROCKET (code number 22 295 20)

### 1. Description

This sprocket is made of chromium-nickel steel and weighs no more than 16 grammes. Thanks to this light weight the forces of acceleration are small, thus minimizing wear of the intermittent unit. Thanks to the milled-in tooth base the film lies perfectly flat on the running surfaces, thus reducing wear of the film to a minimum. This also helps to produce a very steady picture on the screen. Only in exceptional cases should this intermittent sprocket be removed. It should never be taken down for cleaning, as this can always be done with a tooth brush.

Should the teeth show wear on one side, the sprocket can be reversed, thus doubling its life.

### 2. Removing and replacing

If it should be necessary to take down the sprocket, for instance when the teeth are badly worn on one side or when a new sprocket has to be put in, turn the axial fixing screw about half a turn to the left and slide the sprocket off its spindle. Before putting it back carefully clean and grease the spindle and boring, then slide the sprocket onto the spindle over the studs until it comes up against the stop; it is thereby automatically aligned.

The fixing screw is then turned to the right, not too tightly. When screwing and unscrewing this screw the cross must be well blocked. In the case of sprockets that cannot be removed from the spindle by hand, Philips sprocket-puller code number 22 468 76 (fig. 6) can be used. It is to be noted that this tool has left-hand thread.

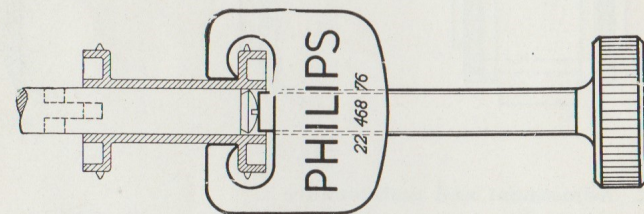
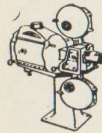

Fig. 6



FP 5-6-7

§ 7. **32-TOOTH SPROCKETS WITH MANUAL FILM-LOOP CORRECTORS** (code number 22 443 40)

1. **Description**

As already remarked, manual loop correctors are used exclusively with the FP 6 and FP 7 projectors. The sprockets are of chrome nickel steel. Top and bottom sprockets are identical. For details see sheet AA.C-2.

2. **Removing and replacing**

After the fixing screw has been loosened the sprockets can be slid off the spindles. The head of the screw is accessible from the side of the manual loop corrector by turning the milled ring. The red spot on the front side of the sprocket comes to lie over the screw hole between the two rows of teeth of the sprocket. When putting back the sprocket it must come up against the stop. When it is automatically aligned. It can only be placed on the spindle in one direction and is not, therefore, reversible. Care must be taken that the fixing screw is centred on the flattened plane of the spindle.

§ 8. **32-TOOTH SPROCKETS WITHOUT MANUAL FILM-LOOP CORRECTORS** (code number 22 413 89)

1. **Description**

These sprockets are used with the FP 5 projectors. Top and bottom sprockets are identical.

2. **Removing and replacing**

After the fixing screw has been loosened the sprockets can be slid off the spindles. Just as with the intermittent sprocket, these sprockets can be reversed. When putting them back on the spindle see that they come up against the stop, so that they are automatically aligned. The fixing screw must be centred on the flattened plane of the spindle.

**AA.E-13**

1.11.47

§ 9. **PAD ROLLERS** (figs 7 and 8; code number 22 414 69)

1. **Dismantling frame and rollers**

After removing the long screw "2" the frame can be drawn off the hollow pin. The two rollers can be slid off the spindle after removing screws "1" and "3".

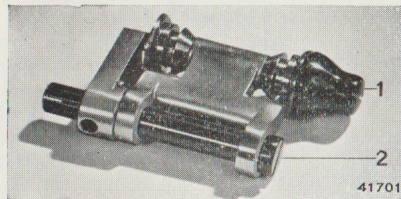

Fig. 7

2. **Removing the complete pad rollers**

This may be done only when absolutely necessary.

Turn the long screw "2" two turns anti-clockwise and after tapping the head of the screw with a hammer

the roller comes away; to protect the head of the screw use a piece of wood.

3. **Assembling and adjusting**

Place the roller in the approximately correct position and tighten screw "2" lightly. Shut the roller and adjust so that:

- a. flanges of the rollers run free of the sprocket;
- b. sufficient space is left between the running faces of the sprocket and the rollers so that with two thicknesses of film the rollers run lightly and with three thicknesses they run heavily.

Then tighten screw "2" and check the adjustment.

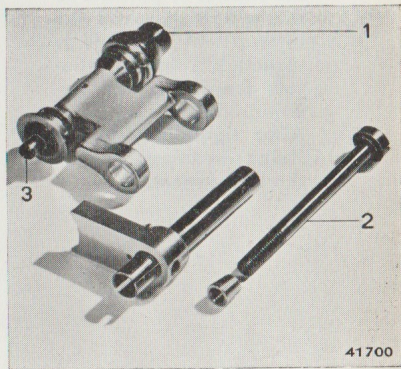
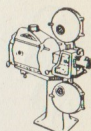

Fig 8

4. **Lubrication**

After removing screw "1" a lubricating hole is exposed. A few drops of spindle oil dropped through the hollow pin is sufficient to lubricate the two pressure rollers from outside.



FP 5-6-7

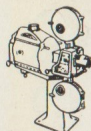

EP 5-6-7

**AA.E-14**

1.11.47

§ 10. **DRUM SHUTTER** (figs 9 and 10; code number 22 413 65)

1. **Description** (fig. 9)

The drum shutter is made of steel throughout, so that there is no danger of deformation even when a 150 amp. arc lamp is used. The shutter is provided with two centrifugal blades which automatically cut off the light beam if the projector should lose speed or stop entirely.

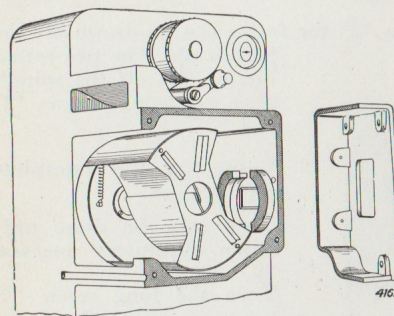

Fig. 9

2. **Adjusting** (fig. 10)

Remove the shutter cover and turn the fixing screws "1", "2" and "3" one turn to the left. The shutter can then be rotated on its spindle.

The correct shutter adjustment is obtained when the mark line on the shutter is parallel to the optical axis and the intermittent sprocket is turned  $2\frac{2}{3}$  tooth intervals from the rest position.

After tightening up the fixingscrews again check the adjustment.

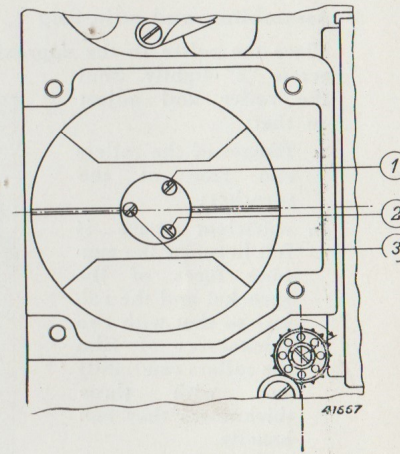

Fig. 10

**AA.E-15**

1.11.47

§ 11. **COOLING INSTRUCTIONS**

Unless there are specific cooling regulations in force no special cooling is absolutely necessary, but water-cooling is always recommendable, because:

- a. it reduces buckling, shrinking and drying-out of the film, thereby preserving quality of reproduction and lengthening the life of the film;
- b. the projector mechanism is kept perfectly cool even under continuous operation, so that the oil fully retains its lubricating properties.

In view of these advantages it is recommended to use water-cooling at least when arc lamps of over 45 amp. are used. If local regulations demand it then air-cooling with a separate air compressor is employed; the FP 5, FP 6 and FP 7 projectors are suitable for this.

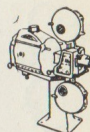

FP 5-6-7

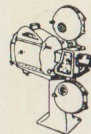

FP 5-6-7

**AA.E-16**

1.11.47

§ 12. **AIR-COOLING**

1. **Description**

In addition to the cooling action of the ventilating blades of the drum shutter, the runner plate and film can be cooled by means of a separate air compressor. For this purpose the FP 5, FP 6 and FP 7 projectors are equipped with built-in cooling air ducts, beginning in the top hollow guide rod of the lens holder and having their outlet over the mask in front of and behind the film. In this way the film and runner plate are well cooled on both sides just at the place where they get heated most.

2. **Installing the system**

For connecting up the air-cooling system see the instructions for use given with the air compressor. For the installation of the air pipes see sheet AA.J-2, fig. 1.

The funnel "2" may be of any size; it may be made of galvanised sheet-iron abt. 0.05" thick.

The length of delivery and discharge piping "3" and "4" depends upon the height of the projection room windows from the floor (see sheet AA.J, fig. 1).

The small pipe "14" must have its outlet lower than the drain cock "9", as otherwise when the water is drained off it will flow through the cock "9" instead of through the pipe "14". For the correct positioning of the supply and discharge pipes "3" and "4" see sheet AA.J, fig. 1.

The water-cooling connections are shown diagrammatically in fig. 12. The water supply pipe "3" has a main cock "1", a reducing T-piece "19" and a reducing valve "17". The supply cock "8" of the water-cooling system is connected to the reducing valve with a rubber tube "5".

The discharge pipe "10" is connected with rubber tube "6" to the pipe "14" with its outlet above the funnel "2" on the discharge pipe "4". The funnel facilitates checking the quantity of water flowing through, which should be regulated by means of the reducing valve "17" to about one-third pint (one-fifth litre) per minute.

#### 4. Operation and maintenance

The following rules should be applied:

- It is advisable not to put the water into circulation until the projector has been running 5—10 minutes, so as to avoid condensation.
- In frosty weather drain off the water after the last performance. Shut the main cock "1" and open drain cock "9". After the water has been drained off it is advisable to blow out the cooling system through the opened cock "9", to which a length of rubber tubing can be attached for the purpose.

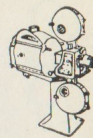

FP 5-6-7

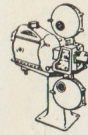

FP 5-6-7

### § 14. AUTOMATIC FILM-RUPTURE DEVICE TYPE 8669

#### 1. Description

Normally only the FP 7 projector is provided with an automatic film-rupture device; if desired it can also be fitted on the FP 5 and FP 6 projectors.

This device consists of two parts, the light cut-off and the mercury switches.

The **light cut-off** intercepts the light beam to the film as soon as this stops in the gate while the projector is still running.

It acts in the following way. If, for instance in case of breakage, the film stops in the gate, the film still coming through the top sprocket makes the film loop larger and this strikes against an arm "10", lifting it up. This displaces the support "9" under the lever "11", which then falls, together with the rod "8" and light cut-off "7". The most dangerous place for a film-rupture, the gate, where the film could immediately catch fire, is thus very simply safeguarded.

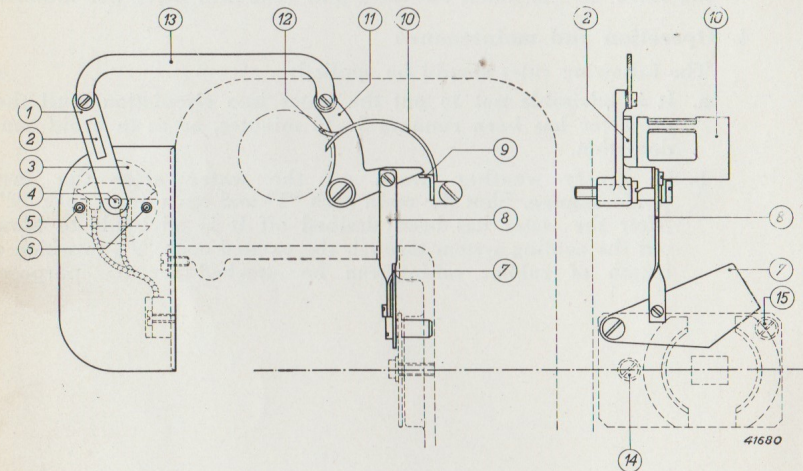

Fig. 13

The **mercury switches** ensure that as soon as the light cut-off "7" falls the motor current and exciter lamp supply are cut off. The holder "3" contains two mercury switches and has room for a third: it is fitted rotatable around the shaft "4" and connected via lever "1" and rod "13" to lever "11".

The mercury switches work as follows:

As soon as the automatic light cut-off comes into action the holder "3" falls and the mercury switches interrupt the motor and exciter lamp currents. The film-rupture device is returned to its original position by pressing the stud "2" to the left.

When a film is threaded in care should be taken that the distance between the top film loop and arm "10" is about half an inch (1.5 cm).

## 2. Mounting

- For the manner of mounting see fig. 13 and for the electrical connections see sheets AA.B, figs 5 and 8.
- After the angle of inclination of the projector has been adjusted the holder has to be so placed that the mercury tubes are horizontal when in the position in which they have to make contact. To find this position the holder "3" can be turned after loosening the screws "5" and "6" half a turn; these screws must be tightened up again after the adjustment has been made.
- See that the connecting wires from the mercury switches do not hinder operation; if necessary they can be shortened.
- Check the light cut-off, levers and rods for easy movement. All pivoting points should be oiled with a little spindle oil once a month.
- Arm "10" has a stop "12" which if necessary can be bent slightly to make sure that the arm does not touch the top sprocket.
- For replacement of a mercury switch only the two connecting wires need be disconnected.

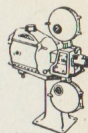

FP 5-6-7

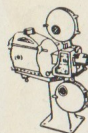

FP 5-6-7

## § 15. TOP AND BOTTOM SPOOL BOXES; WEDGE BLOCKS

## 1. Description

Spool boxes can be supplied in two sizes, for 3000 ft (900 m) spools and for 4000 ft (1300 m) spools.

All spool box spindles run in ball-bearings, so that seizing is precluded.

Felt-friction washers are used; the felt has to be saturated periodically in cardan oil.

The safety fire-traps are described on sheet AA.E-25.

If the projector is inclined forward at a large angle, or if 4000 ft spool boxes are used, the projector would have to be placed at a good distance away from the front wall of the projection room, as otherwise the top spool box would come up against this wall. As a result the space available at the back is reduced and, moreover, when projection lenses of very short focal length are used, it may happen that the light beam does not pass freely through the projection window.

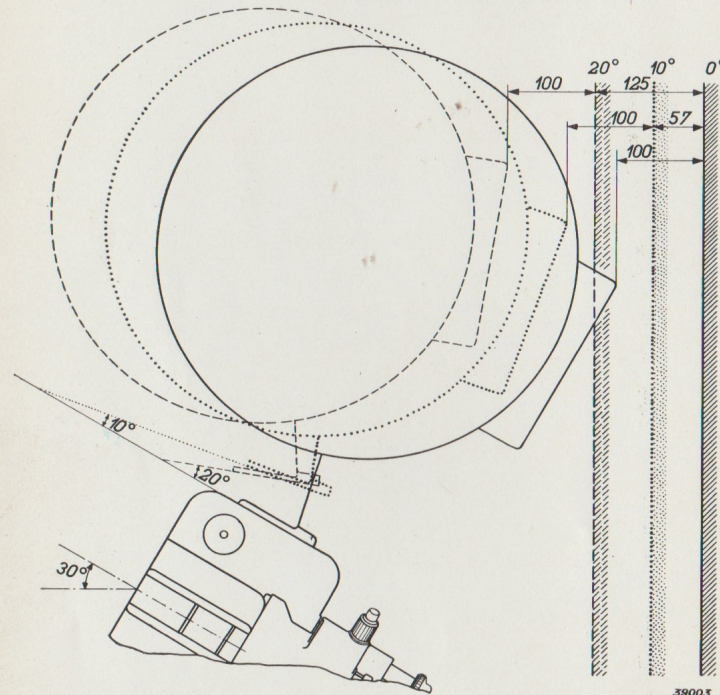

Fig. 14

This difficulty may be overcome by inclining the top spool box backwards by inserting a wedge block, thus enabling the projector to be placed closer to the front wall of the projection room. Fig. 14 shows how this is done. Philips supply two kinds of wedge blocks:

- with an angle of  $10^\circ$ : type 8644
- with an angle of  $20^\circ$ : type 8645.

## 2. Inserting the wedge blocks

In the case of the FP 5 and FP 6 projectors the wedge blocks can be inserted directly between the projector and the spool box arm. When inserting a block in the FP 7 projector a new slit for the film has to be cut underneath the safety fire-trap and the existing slit covered with a small plate.

## 3. Adjusting the friction couplings (figs 15 and 16)

The friction couplings are adjusted by turning nut "5". They should be kept as loose as possible but still tight enough for the film to be kept taut while running. Further the friction coupling of the bottom spool box must be so adjusted that the film is kept taut when starting up and remains so until the end of the reel. In the case of the top spool box the film must be kept taut when the machine is switched off.

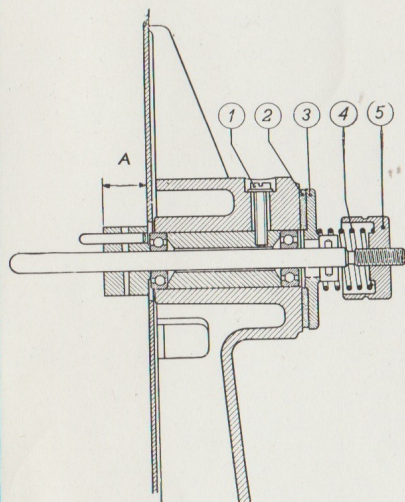

Fig. 15

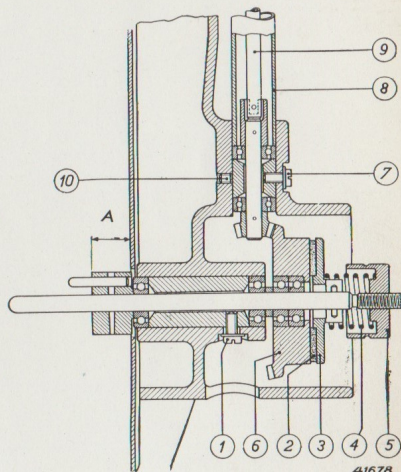
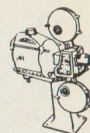

Fig. 16

See that the spools used have a core diameter of at least 5" (127 mm), which has been standardized for a number of years already.

If the core diameter is less the film loop will at first remain loose, as the peripheral velocity of a small core is less than the speed of the film.



FP 5-6-7

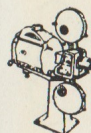

FP 5-6-7

## 4. Dismantling the spindles

The following parts can be removed from the top and bottom spool spindles without the use of tools:

adjusting nut . . . . .	"5"
pressure spring . . . . .	"4"
pressure washer . . . . .	"3"
felt washer . . . . .	"2"

and from the bottom spool box also:

gear wheel . . . . .	"6"
----------------------	-----

After removing screw "1" the spool spindles with ball-bearings and the bush can be drawn out. If it is required to remove the vertical driving shaft it is necessary first to take off the bottom spool box, then the dust tube "8" and coupling shaft "9". By taking out screw "7" and loosening screw "10" (fig. 16) the vertical driving shaft can be removed together with the ball-bearings and the bush.

When replacing the spindles and driving shaft keep to the adjusting dimension "A" (see figs 15 and 16), which for 3000 ft (900 m) spool boxes is 0.807" (20.5 mm) and for 4000 ft (1300 m) spool boxes 0.787" (20 mm).

## § 16. SAFETY FIRE-TRAPS (fig. 17, code number 22 416 30)

## 1. Description

Each safety fire-trap is fitted with two rollers, one flanged. Both rollers are interchangeable; the correct place depends upon the direction of rotation of the spools. The top spool can rotate clockwise or anti-clockwise as desired by the operator, while the bottom spool always rotates clockwise. For the correct positioning of the rollers the following rule applies.

**Top spool box:**

flanged roller on the right if the spool must turn clockwise,  
flanged roller on the left if the spool must turn anti-clockwise.

**Bottom spool box:**

flanged roller on the right.

## 2. Dismantling

Loosen screws "1" and "4" and turn the lock washers. The hollow spindles can then be drawn forward and the rollers removed.

## 3. Lubricating

The rollers can be lubricated through the hollow spindles at the points "2" and "3".

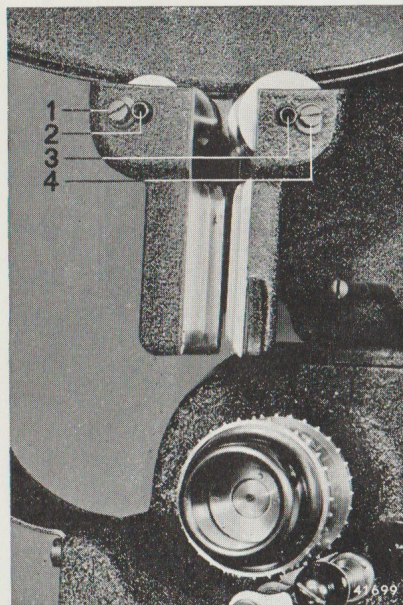
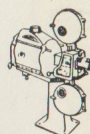
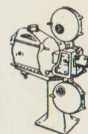

Fig. 17

It is of very great importance to clean the safety fire-traps every day and to check the free running of the rollers. Contamination causes damage to the film.



FP 5-6-7



FP 5-6-7

## § 17. SAFETY CLUTCH

## 1. Description

This clutch serves to prevent damage to the gear wheels in case the projector mechanism should suddenly seize up. It consists in the driving gear wheel of the motor shaft (or of the belt pulley shaft) "2" being pressed onto the shaft with a certain force (fig. 18). The friction is so adjusted that any slipping is impossible during normal operation.

## 2. Adjusting (fig. 18)

Remove the motor (or the bearing plate for the pulley) and set it up with the shaft horizontal.

Clamp the free end of the shaft to stop it turning and remove the oil splash guard "1". Clamp on gear wheel "2" the special

balanced arm "6" (fig. 19) code number 22 440 39.

By turning the adjusting nut "4" the friction is adjusted in such a way that a weight of 6.6 lbs (3 kg) suspended from one end of the arm does not cause the gear wheel "2" to rotate around the shaft. When an additional weight of 0.66 lbs (300 grammes) is added the gear wheel should begin to rotate. The check nut "3" is then screwed on tight against the nut "4" and the adjustment is checked.

If arm "6" is not available it can be made, with reference to fig. 19.

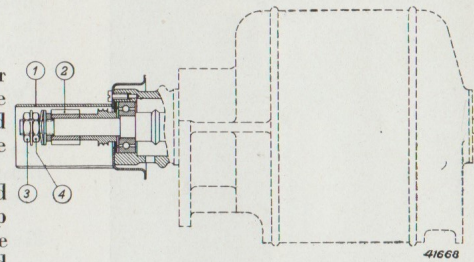

Fig. 18

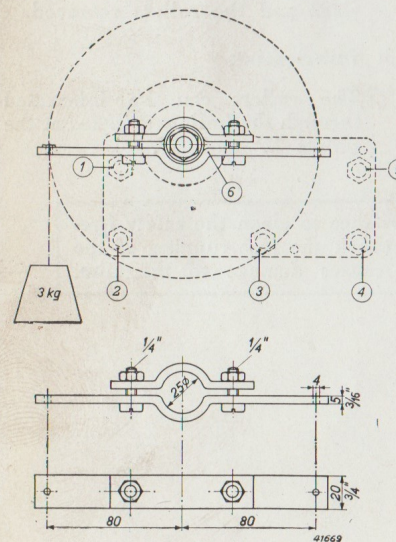

Fig. 19

In case of faulty action one can make shift by tightening nut "4" and then nut "3" until gear wheel "2" can no longer be rotated by hand around the shaft (clamped tight). Of course in this case the safety clutch will no longer operate if the projector should seize up, and it is therefore of importance that the clutch should be readjusted as soon as possible in the manner indicated above.



## § 18. ADJUSTABLE GUIDE ROLLER IN THE FP 7 PROJECTOR

## 1. Description

As is known, in long halls the sound takes more time to reach the back seats than it does in short halls. It may, therefore, sometimes be preferred to advance the sound a little, and with the FP 7 projector this can be done in the following way.

The roller "3" (sheet AA.C, fig. 1) is adjusted in the direction of the arrow so as to reduce the distance travelled by the film between the mask and the sound-head. The film can then be threaded in a little shorter and the sound reproduction is slightly advanced ahead of the corresponding picture.

The best result is obtained by adjusting the "picture-sound" distance, i.e. the distance from the centre of the mask to the spot where the sound is scanned in the sound-head, according to the table below.

Length of the hall	up to 115-ft (35 m)	115—150 ft (35—45 m)	150—180 ft (45—55 m)	180—215 ft (55—65 m)
Picture-sound distance in frames	20 (normal)	19	18 $\frac{3}{4}$	18 $\frac{1}{2}$

## 2. Adjusting

After turning pin "1" one turn back (first removing the small guide roller "2") roller "3" can be adjusted. Roller "3" is then moved so that the film loop underneath the intermittent sprocket is of the desired size for the correct picture-sound distance (see sheet AA.C-1).

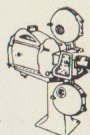

FP 5-6-7

## VI DISMANTLING THE INTERNAL PARTS OF THE PROJECTOR

(Fig. 1)

The assembling and dismantling of internal parts is the work of skilled sound-film technicians and should not be undertaken by others unless absolutely necessary.

### 1. Intermittent unit

Open the lens holder, take out the runner plate, open the pad roller of the intermittent sprocket, turn the framing knob as far as possible to the right and take off the back cover.

With the framing device in the extreme positions the two screws "4" and "5" become accessible at the front of the projector and after these have been loosened the whole intermittent unit with sprocket can be carefully taken out; the oil splash guard "13" inside the housing on the left has to be pushed aside a little. When replacing the intermittent unit do not forget to adjust the shutter (see sheet AA.E-14).

### 2. Combined gauze and magnetic filter

Unscrew the oil drain plug "11" with a 27 mm wrench, drain off the oil and pull out the filter "12".

### 3. Oil delivery pipe

This pipe is fixed to the pump housing with the hollow screw "14" and to the side of the projector with the screws "15" and "20"; it can be removed by unscrewing these screws. In order to avoid oil leakage, before putting the pipe back the two copper washers for the hollow screw "14" must be re-annealed.

### 4. Oil pump

Loosen screws "8", "9" and "10", take out the combined gauze and magnetic filter (see point 2), the oil delivery pipe (see point 3) and then the oil pump, pushing the oil splash guard "13" aside.

### 5. Flange motor and pulley bearing plate

The motor or bearing plate can be removed by loosening the bolts "1", "2" "3", "4" and "5" (sheet AA.E, fig. 18) with a special wrench, code number 22 443 29. The projector need not be drained unless it is inclined at a large angle. Take care not to damage the gasket "21". After reassembling and when the projector has been running again a few hours tighten up the bolts uniformly.

### 6. Bearing supports of the top and bottom sprockets

Open the pad roller on the operating side of the projector, remove the sprocket and, if the bottom sprocket bearing support is to be taken down, also the inching knob, and, in the case of the upper sprocket bearing support, the oil delivery pipe (see point 3). Finally take out the screws "6" and "7" or "18" and "19" respectively, at the back.

### 7. Bearing support of the shutter spindle

After loosening the screws "31", "38" and "39" remove the cover on the operating side. Loosen screws "26", "29" and "30" and take the shutter off. By loosening screws "27", "33" and "37" the bearing support can then be taken out.

Axial adjustment can be made by first loosening the lock screw "25" one turn and then adjusting the screw "24" in order to obtain the smallest possible but still perceptible axial play; after tightening up lock screw "25" check the adjustment. Before remounting the bearing support re-anneal the three copper washers "28", "32" and "36" in order to avoid oil leakage. Finally readjust the shutter (see sheet AA.E-14).

### 8. Main shaft

First remove the intermittent unit (see point 1), the bearing support of the shutter spindle (point 7) and the flange motor or the pulley bearing

plate (point 5), then loosen the screws "34" and "35", or "16" and "17" respectively of the lower and upper bearing supports of the main shaft, and also the large screw "1" for the guide fork "2". Slide the main shaft upward and take out of the projector. When reassembling do not forget to put in the steel ring "3" and readjust the shutter (see sheet AA.E-14).

The oil pump, flange motor, pulley bearing plate, and the bearing supports of top and bottom sprockets, shutter spindle and main shaft are all pinned. When these parts are remounted after dismantling they therefore need no readjustment. If, however, they are replaced the new ones may not be pinned, because of possible fouling of the projector; in that case the gear wheel transmission must be adjusted to the smallest possible yet still perceptible play.

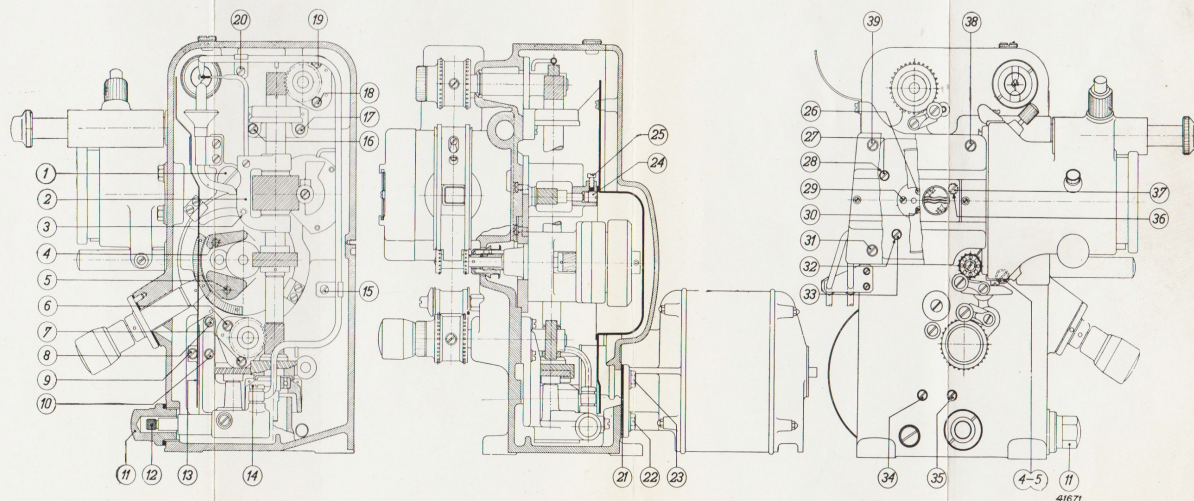
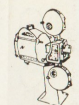

Fig. 1

AA.F-1  
1.11.47



FP 5-6-7

## VII DIFFERENT MOTORS

## § 1. Converting a belt-driven projector into one with flange motor for 50 c/s mains

1. Remove:
  - the belt guard,
  - the belt,
  - the motor with pulley,
  - the motor support,
  - the bearing plate with pulley.
2. Mount the flange motor (see sheet AA.F-1).  
The code number of the flange motor complete with gear wheel, safety clutch and oil splash guard for 50 c/s mains is 22 413 95.
3. For changing over from 220 V to 110 V see sheet AA.B-5.

## § 2. Converting a projector with flange motor into a belt-driven one for 40, 50, 60 and 100 c/s mains

1. Remove:
  - the flange motor.
2. Mount:
  - a) the bearing plate with pulley, code number 22 415 31 (see sheet AA.F-1),
  - b) the motor support,
  - c) the motor with pulley,
  - d) the belt,
  - e) the belt guard.
 } see sheet AA.B-5

The parts "b" to "e" can be ordered for different mains frequencies under the following type numbers:

c/s	40	50	60	100
Type No.	8601/00	8602/00	8603/00	8604/00

3. For changing over from 220 V to 110 V, see sheet AA.B-5.

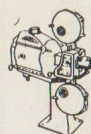

FP 5-6-7

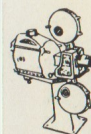

FP 5-6-7

## § 3. Converting a projector with flange motor into a belt-driven one for D.C. mains

1. Remove:
  - the flange motor.
2. Mount:
  - a) the bearing plate with pulley, code number 22 415 31 (see sheet AA.F-1),
  - b) the motor support,
  - c) the motor with pulley,
  - d) the starting resistance,
  - e) the belt,
  - f) the belt guard,
  - g) the film-speed indicator type 8662/00 (see sheet AA.B-10).
 } see sheet AA.B-5

The parts "b" to "f" can be ordered for different D.C. mains under the following type numbers:

Voltage	110 V	220 V
Type No.	8606/00	8605/00

## VIII REAR PROJECTION AND FRONT PROJECTION WITH SHORT FOCUS LENSES

With rear projection the projection room is behind the screen; in contrast with front projection, a mirrored picture has to be projected on the screen, and for this the projector has to be fitted up in the following way: The whole apparatus is installed in the normal manner, but the film has to be threaded in with the emulsion side facing the lens, so that the sound track comes to lie on the opposite side. This involves the following changes in the apparatus:

1. The mask plate is turned 180° around the optical axis, so that the spring lips come to lie on the sound-track side. The dull side, where the word "Film" is engraved, is kept facing the film.
2. The projection lens has to be mounted in a special eccentric adapter 82.5/42.5 mm, type 8684/00; only lens holders of 82.5 mm, type 8681/00, can be used. The adapters have to be fixed in a certain position: in the front rim is a groove with the word "Top" on the inside, and this has to be uppermost.
3. Type 3837/00 sound-head normally used with FP 5 and FP 6 projectors has to be replaced by type 3837/30 sound-head specially fitted for rear projection. The FP 7 projector with incorporated sound-head cannot be supplied for rear projection.

Since with rear projection the projection distance available is generally very limited, it will often be necessary to use lenses with a short focal length. In that case the light distribution as well as the efficiency can be considerably improved by using a condenser lens. If such a lens is used in the FP 5 and FP 6 the normal mask plate has to be replaced by a special one provided with an annular segment to take the condenser lens (see fig. 1). This special mask is supplied under the type number 8663/00.

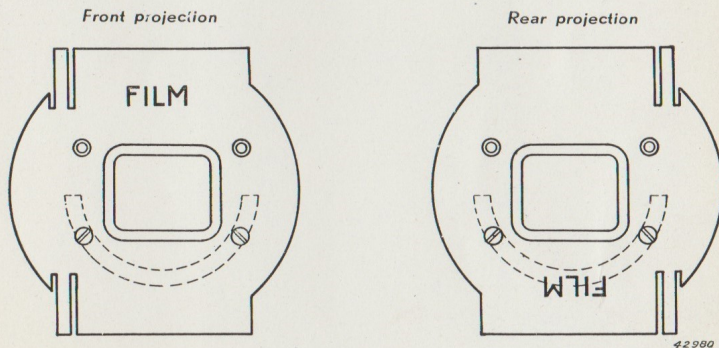
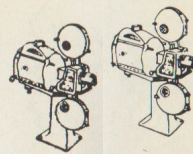

Fig. 1



FP 5-6-7 FP 5-6-7

The following table gives the numbers of the condenser lenses to be used with the different projection lenses.

Projection lens		Condenser lens		
Focal length		Focal length		Type No.
in mm	in inches	in mm	in inches	
40	1½	65	2½	8688
45	1¾	80	3¼	8689
50	2	95	3¾	8690
55, 60, 65	2¼—2½	110	4¼	8691
70, 75, 80, 85	2¾—3½	125	5	8692

In front projection with short focus lenses the use of condenser lenses offers the same advantages as in rear projection and is to be recommended. In front projection the above-mentioned annular segment has to be fitted on the special mask plate in a different way than required for rear projection — see fig. 1. In both cases, however, the segment is fitted on the bright side of the mask.



AA.J-1

1.11.47

## IX EQUIPMENT OF THE PROJECTION ROOM

### § 1. DIMENSIONS

It is recommendable to arrange for ample space in the projection room. Fig. 1 gives a general idea of the installation where two projectors are used. Reference must also be made to the local regulations regarding fire safety, etc.

### § 2. WATER-COOLING AND AIR-COOLING

The drawing shows the position of the air and water cooling pipes against the front wall of the projection room.

### § 3. APERTURES FOR THE PROJECTION ROOM WINDOWS

The distance between the windows is given in fig. 1. The height of the windows from the floor and the position of the projectors at a certain angle of inclination can be determined with the aid of the plan (fig. 3) and accompanying scale (fig. 2).

Fig. 3 is the plan of the projector on a pedestal. On the scale (fig. 2) the graduation V represents the front wall of the projection room, and graduation H the floor of the projection room. If the scale (fig. 2) is placed upon the projector drawing at different angles of inclination the same effect is obtained as when actually inclining the projector in the projection room.

The aim should always be to place the projector as close as possible to the front wall so as to leave plenty of free space behind the machine. However, a certain minimum distance has to be kept between the foremost point of the projector and the front wall of the projection room. In the table below the points are given which when using 3000 or 4000 ft spool boxes are closest to the front wall of the room.

Projector inclined forward						Projector inclined backward	
3000 ft (900 m) spool boxes			4000 ft (1300 m) spool boxes			3000 ft (900 m) spool boxes	4000 ft (1300 m) spool boxes
without wedge	with 10° wedge	with 20° wedge	without wedge	with 10° wedge	with 20° wedge		
A	A <sub>10</sub>	A <sub>20</sub>	A'	A' <sub>10</sub>	A' <sub>20</sub>	B	B'

When the angle of inclination is small it may be that the ornamental nut of the upper guide rod of the lens holder will be the point closest to the front wall of the projection room, so that also point C must be taken into account.

When a lantern slide attachment is used the lens holder of this attachment is often closer to the front wall than any of the points mentioned above. In that case, therefore, take the point  $f_{\text{dia}}$  into account, which will depend upon the focal length of the slide lens used.

The following examples apply both for installations on the normal pedestal and for those mounted on the de luxe pedestal with height adjustment (when the latter is in the lowest position). If the normal pedestal is placed on a raised base or if the de luxe pedestal is elevated then the height of elevation has to be added to the height from the pedestal ground plane to the centre of the projection window.

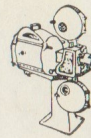

FP 5-6-7

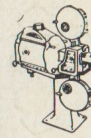

FP 5-6-7

AA.J-2

1.11.47

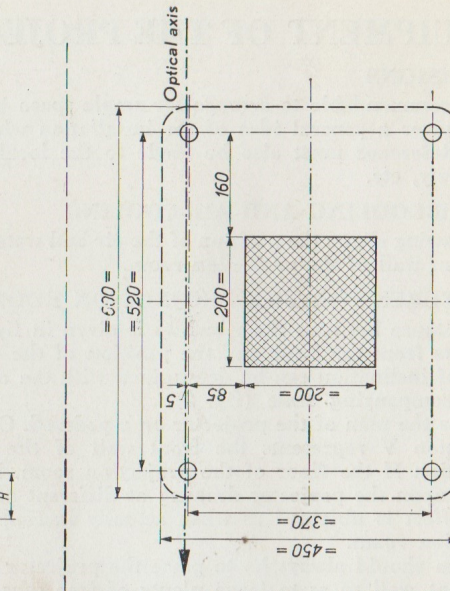
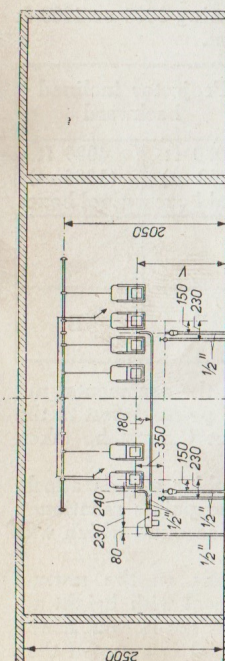
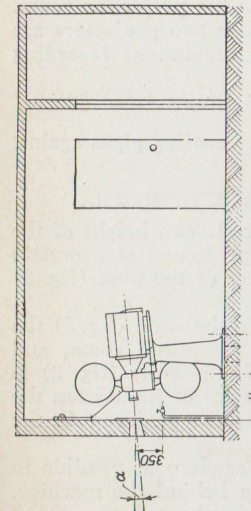

Ground plan of projector pedestal with aperture for passing through the tubes

Fig. 1

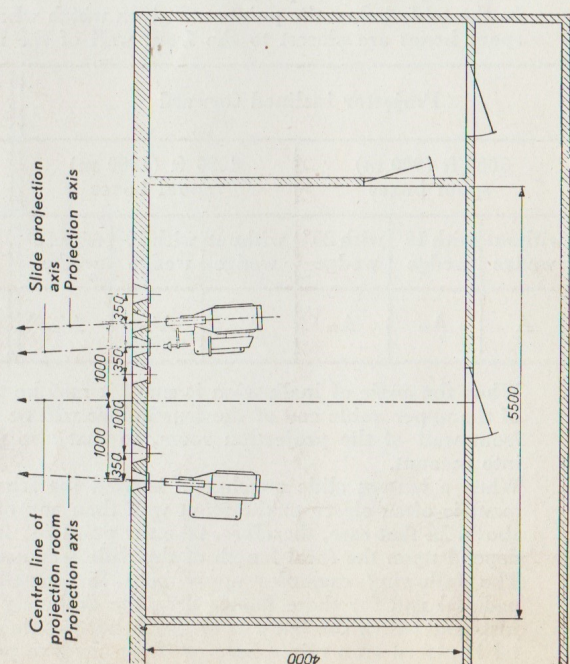

One then proceeds as follows:

**Example 1**

Projection angle 15° downward, 4000 ft (1300 m) spool boxes, no lantern slide attachment, no wedge blocks.

Points to be considered: A' or C.

Lay leg H on the line indicated by +15° and slide the scale to the left till leg V coincides with the centre of A'.

We then read:

1. On leg H at +15° the number 730. This means that the distance from the centre of the foremost bolt hole in the pedestal to the front wall of the projection room must be 730 mm, measured horizontally.
2. At the point where leg V intersects the optical axis, the number 965, which means that the centre of the projection window is 965 mm above the ground plane of the pedestal.

**Example 2**

Projection angle 5° upward, 3000 ft (900 m) spool boxes, lantern slide attachment with focal length  $f_{sl} = 550$  mm, no wedge blocks.

Points to be considered: B, C,  $f_{sl}$ .

Lay leg H on the line indicated by -5° and shift the scale to the left till leg V coincides with the centre of  $f_{sl} = 550$ .

We then read:

1. On leg H at -5°, the number 525, so that the distance from the centre of the foremost bolt hole in the pedestal to the front wall is 525 mm, measured horizontally.
2. Where leg V intersects the optical axis, the number 1250, indicating that 1250 mm is the height of the centre of the projection window from the ground plane of the pedestal.

**Example 3**

Projection angle 30° downward, 3000 ft (900 m) spool boxes, lantern slide attachment with focal length  $f_{sl} = 400$  mm, wedge block 20°.

Points to be considered:  $A_{20}$ , C,  $f_{sl}$ .

Lay leg H on the +30° line and shift the scale to the left till leg V coincides with the centre of  $A_{20}$ .

Read off:

1. On leg H at +30°, the number 680, thus 680 mm is the distance from the centre of the foremost pedestal bolt hole to the front wall of the projection room.
2. Leg V intersects the optical axis at the figure 765, which means that the centre of the projection window is 765 mm above the pedestal ground plane.

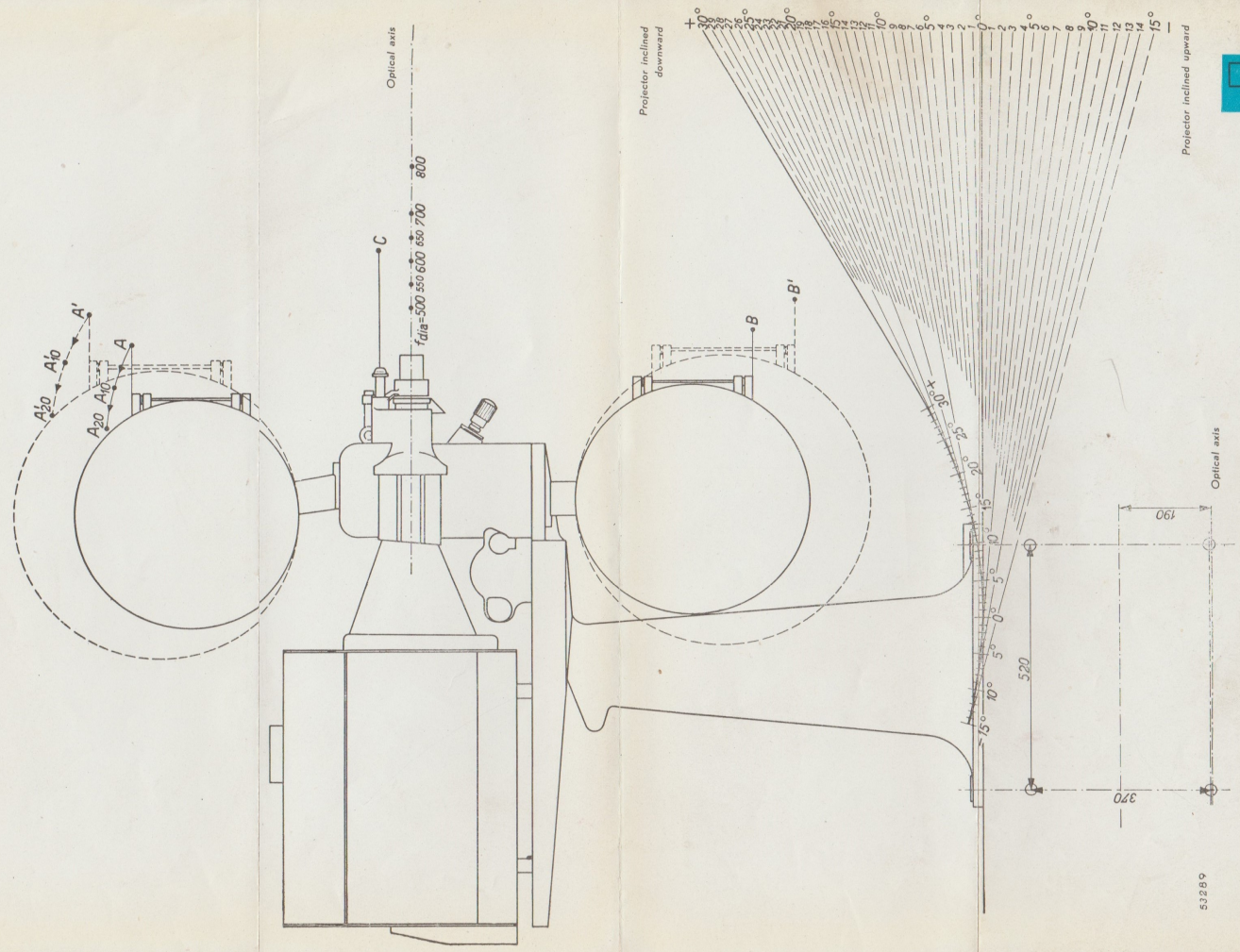

AAJ-1  
1-11-47



FP 5-6-7

Fig. 3

53289



AA.K-1

1.11.47

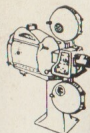

## X LIST OF SPARES AND TOOLS

The following spares and tools are supplied free of charge with every outfit.

FP 5-6-7

Number or length	Description	Code number
1	Pair of pressure skates . . . . .	22 741 17
1	Wrench 27 mm . . . . .	71 470 19
1	Special wrench for motor bolts . . . . .	22 443 29
1	Screw-driver 6 × 12 mm . . . . .	71 471 06
1	Screw-driver 4 mm . . . . .	74 471 00
1	Cleaning rag . . . . .	40 012 00
1	Lens wiper . . . . .	70 010 68
1	Tooth brush . . . . .	40 010 50
1	Oil funnel . . . . .	40 970 10
1	Packing ring . . . . .	22 415 45
1	Packing ring . . . . .	22 456 03
1	Felt washer . . . . .	22 415 78
41" (105 cm)	Velvet tape for velvet-covered runners . . . . .	06 602 69

## XI SUGGESTIONS FOR STOCKING SPARES

It is advisable always to keep a stock of spares in every projection room, so that in case of damage or heavy wear the parts can be replaced at once and thus avoid any interruption in performance.

Suggestions are given below for a small stock and for a larger one.

### § 1. FOR THE PROJECTOR

#### a. A small stock for FP 5 and FP 6 projectors

Number or length	Description	Code number
1	Steel runner plate . . . . .	22 415 12
1	Velvet-covered runner plate . . . . .	22 415 46
41" (105 cm)	Velvet tape . . . . .	06 602 69
1	Pair of pressure skates . . . . .	22 741 17
1	Pad roller . . . . .	22 414 69
1	Intermittent sprocket . . . . .	22 295 20
1	Top (bottom) sprocket without manual loop corrector (for FP 5) . . . . .	22 413 89
	or	
1	Top (bottom) sprocket with manual loop corrector (for FP 6) . . . . .	22 443 40
1	Mask plate . . . . .	22 416 89
1	Ball-bearing for main shaft . . . . .	89 181 07
1	Ball-bearing for vertical driving shaft of bottom spool box . . . . .	22 926 30
1	Ball-bearing for spool box spindles . . . . .	89 181 04
1	Pressure spring of spool box lock . . . . .	22 452 69
1	Pressure spring for lens holder guide rod . . . . .	22 415 43
1	Shutter spring . . . . .	22 413 32
1	Tube Necol cement . . . . .	02 110 15
1	Packing ring . . . . .	22 456 03
3	Packing rings . . . . .	22 414 61

#### b. A small stock for FP 7 projector

In addition to the list sub a:

Number	Description	Code or type number
1	Photocell . . . . .	3533
4	Exciter lamps . . . . .	3874 (abt. 6 V, 1.48 A) or 7251 C (abt. 5 V, 4.0 A)

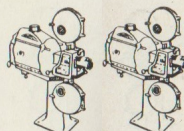

FP 5-6-7 FP 5-6-7

#### c. A larger stock for FP 5 and FP 6 projectors

In addition to the list sub a:

Number	Description	Code number
1	Shutter, complete . . . . .	22 413 65
1	Intermittent unit without sprocket . . . . .	22 416 31
1	Pressure spring for friction coupling of spool spindles . . . . .	22 415 84
1	Oil pump, complete . . . . .	22 417 03
1	Guide roller 26 mm diameter . . . . .	22 265 95
1	Mercury switch for automatic film-rupture device . . . . .	08 525 53

#### d. A larger stock for FP 7 projector

Additional to the lists sub a, b and c:

Number	Description	Code number
1	Light-focusing system complete . . . . .	22 439 27
1	Mirror . . . . .	22 439 21
1	Microscope lens . . . . .	22 439 32
1	Pressure-torsion spring for pressure roller . . . . .	22 413 24

### § 2. FOR THE PEDESTAL AND MOUNTING TABLE

Number	Description	Code number
1	Transformer for framing and pilot lamp supply	E1 290 00
1	Anti-interference capacitor $2 \times 0.5 \mu\text{F}$ for motor switch . . . . .	49 176 15
1	Starting capacitor $4 + 2 \mu\text{F}$ . . . . .	49 176 16

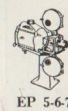

## XII CATALOGUE NUMBERS OF THE PRINCIPAL PARTS

When ordering replacements always quote:

1. **Type number of the equipment**  
This is found on the plate at the back of the mounting table.
2. **Serial number of the projector**  
This is to be found at the back of the projector, on the finished plane to the left of the motor or on the bearing plate for the belt-pulley.

### § 1. PARTS FOR FP 5 AND FP 6 PROJECTORS (fig. 1)

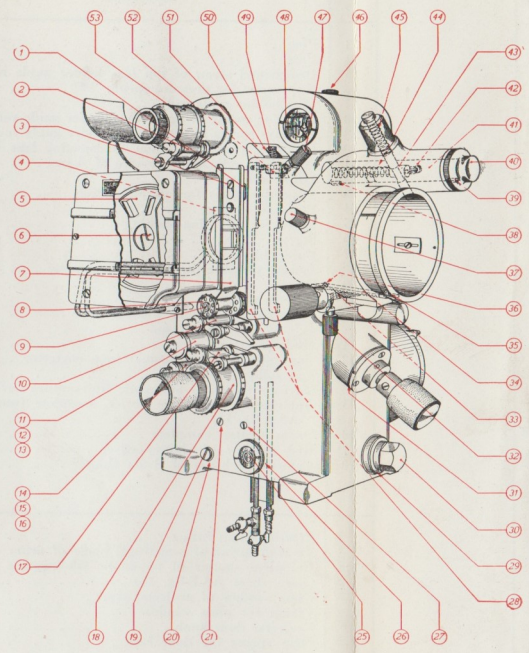

Fig. 1

Item No.	Description	Code number
1	Lateral pressure piece of runner plate . . . . .	22 489 04
2	Pad roller (see fig. 5) . . . . .	22 414 69
3	Screw . . . . .	22 415 18
4	Mask plate . . . . .	22 416 89
5	Drum shutter, complete . . . . .	22 413 65
6	Centrifugal blade of drum shutter . . . . .	22 414 27
7	Runner plate . . . . .	22 415 12
	Velvet-covered runner plate simple finish . . . . .	22 415 46
	Velvet-covered runner plate de luxe finish . . . . .	22 415 93
	41" (105 cm) velvet tape . . . . .	06 602 69
8	Intermittent sprocket . . . . .	22 295 20
9	Fixing screw for intermittent sprocket . . . . .	07 678 08
10	Pad roller (see fig. 5) . . . . .	22 414 69
11	Guide roller . . . . .	22 265 95
12	Pin of guide roller "11" . . . . .	22 415 29
13	Ornamental screw of guide roller "11" . . . . .	22 439 53
14	Guide roller . . . . .	22 439 07
15	Pin of guide roller "14" . . . . .	22 415 29
16	Ornamental screw of guide roller "14" . . . . .	22 415 23
17	Pad roller (see fig. 5) . . . . .	22 414 69
18	Bottom sprocket without manual loop corrector (for FP 5) . . . . .	22 413 89
	Bottom sprocket with manual loop corrector (for FP 6) . . . . .	22 443 40
19	Milled screw . . . . .	22 454 74
20	Packing ring for screw "19" . . . . .	22 415 45
21	Packing ring . . . . .	22 414 61
25	Oil gauge glass . . . . .	22 414 92
26	Packing ring for oil gauge glass "25" . . . . .	22 456 03
27	Packing ring . . . . .	22 414 61
28	Pair of pressure skates . . . . .	22 741 17
29	Packing ring of screw "30" . . . . .	22 456 03
30	Screw for draining off the oil . . . . .	22 417 01
31	Packing disc for framing shaft . . . . .	22 414 84

Item No.	Description	Code number
32	Milled screw . . . . .	22 443 26
33	Worm shaft for micrometer adjustment of the lens . . . . .	22 438 09
34	Gear rack for lens holder 62.5 or 82.5 mm . . . . .	22 438 13
	Gear rack for lens holder 104 mm . . . . .	22 438 18
35	Screw for fixing gear rack "34" . . . . .	22 438 22
36	Screw for fixing gear rack "34" . . . . .	22 438 22
37	Milled screw . . . . .	22 437 99
38	Plug . . . . .	22 443 85
39	Plug . . . . .	22 443 85
40	Ornamental nut for upper lens holder guide rod . . . . .	22 414 62
41	Guide rod for lens holder . . . . .	22 414 65
42	Stop screw for pressure spring "44" . . . . .	07 735 20
43	Bush for spring "44" in upper lens holder guide rod . . . . .	22 415 42
44	Pressure spring in upper lens holder guide rod . . . . .	22 415 43
45	Pressure spring of button for opening lens holder . . . . .	22 438 03
46	Screw for oil-filling opening . . . . .	22 454 74
47	Milled screw . . . . .	22 437 99
48	Inspection glass for oil circulation . . . . .	22 414 22
49	Screw . . . . .	22 438 08
50	Pressure spring . . . . .	22 438 07
51	Guide block . . . . .	22 443 28
52	Spring for adjusting pressure of skates . . . . .	22 438 24
53	Top sprocket without manual loop corrector (for FP 5) . . . . .	22 413 89
	Top sprocket with manual loop corrector (for FP 6) . . . . .	22 443 40
	Framing-lamp fitting . . . . .	22 416 66
	Red window of shutter cover . . . . .	22 415 44
	Tension spring of centrifugal blade of drum shutter . . . . .	22 413 32
	Fire guard (chromium-plated in shutter house behind mask; to be used if no water-cooling is applied) . . . . .	22 417 09
	Inching knob . . . . .	23 705 04
	Framing knob . . . . .	23 705 04
	Lens focusing knob . . . . .	23 705 02

These parts are not shown in the illustration

EP 5-6-7

AA.M-2  
1.11.47

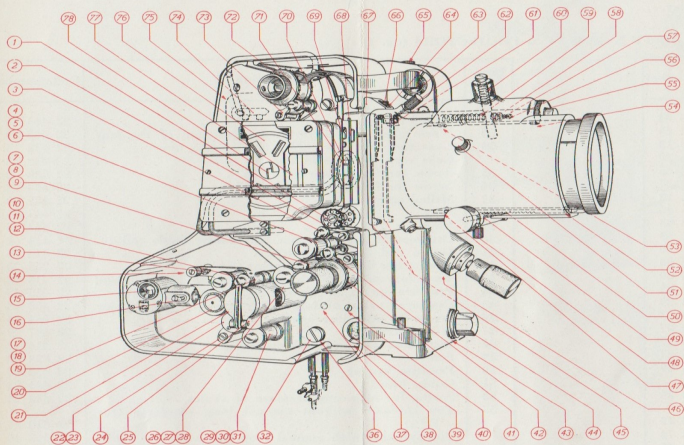

Fig. 2

§ 2. PARTS FOR FP 7 PROJECTOR (Fig. 2)

Item No.	Description	Code number
1	Fixing screw for intermittent sprocket . . . . .	07 678 08
2	Intermittent sprocket . . . . .	22 295 20
3	Pad roller (see fig. 5) . . . . .	22 414 69
4	Guide roller . . . . .	22 265 95
5	Pin for guide roller "4" . . . . .	22 415 29
6	Ornamental screw for guide roller "4" . . . . .	22 439 53
7	Guide roller . . . . .	22 439 07
8	Pin for guide roller "7" . . . . .	22 443 44
9	Ornamental screw for guide roller "7" . . . . .	22 415 23
10	Pressure roller . . . . .	22 443 11
11	Pin for pressure roller "10" . . . . .	22 439 12
12	Ornamental screw for pressure roller "10" . . . . .	22 439 53
13	Set screw . . . . .	22 439 10
14	Steel ring between pressure roller arm and projector housing . . . . .	22 414 99
15	Complete inspection window for adjusting sound track . . . . .	22 439 17
16	Adjusting pin . . . . .	22 439 23
17	Guide roller . . . . .	22 439 07
18	Pin of guide roller "17" . . . . .	22 443 12
19	Ornamental screw of guide roller "17" . . . . .	22 415 23
20	Sound drum . . . . .	22 439 26
21	Lid of exciter lamp holder, with contact spring . . . . .	22 438 83
25	Philitie holder for exciter lamp . . . . .	23 705 06
26	Guide roller . . . . .	22 265 95
27	Pin of guide roller "26" . . . . .	22 443 45
28	Ornamental screw of guide roller "26" . . . . .	22 439 53
29	Guide roller . . . . .	22 265 95
30	Pin of guide roller "29" . . . . .	22 443 45
31	Ornamental screw of guide roller "29" . . . . .	22 439 53
32	Milled screw . . . . .	22 454 74
36	Washer for milled screw "32" . . . . .	22 415 45
37	Packing ring . . . . .	22 414 61
38	Packing ring for oil gauge glass "39" . . . . .	22 456 03
39	Oil gauge glass . . . . .	22 414 92
40	Packing ring . . . . .	22 414 61
41	Bottom sprocket, with manual loop corrector . . . . .	22 443 40
42	Pad roller (see fig. 5) . . . . .	22 414 69
43	Packing ring of screw "44" for draining off oil . . . . .	22 456 03
44	Screw for draining off oil . . . . .	22 417 01
45	Pair of pressure skates . . . . .	22 741 17
46	Packing disc of framing shaft . . . . .	22 414 84
47	Screw for fixing gear rack "50" . . . . .	22 438 22
48	Milled screw . . . . .	22 443 26
49	Worm shaft for micrometer adjustment of lens . . . . .	22 438 09
50	Gear rack for lens holder 104 mμ . . . . .	22 438 18
51	Milled screw . . . . .	22 437 99
52	Screw for fixing gear rack "50" . . . . .	22 438 22

Item No.	Description	Code number
53	Plug . . . . .	22 443 85
54	Plug . . . . .	22 443 85
55	Ornamental screw of top lens holder guide rod . . . . .	22 414 62
56	Stop screw for pressure spring "59" . . . . .	07 735 20
57	Lens holder guide rod . . . . .	22 414 65
58	Bush for spring in upper lens holder guide rod . . . . .	22 415 42
59	Pressure spring in upper lens holder guide rod . . . . .	22 415 43
60	Pressure spring of button for opening lens holder . . . . .	22 438 03
61	Spring for adjusting pressure of skates . . . . .	22 438 24
62	Milled screw . . . . .	22 437 99
63	Inspection glass for oil circulation . . . . .	22 414 22
64	Pressure spring . . . . .	22 438 07
65	Screw for oil-filling opening . . . . .	22 454 74
66	Screw . . . . .	22 438 08
67	Guide block . . . . .	22 443 28
68	Lateral pressure piece for runner plate . . . . .	22 489 04
69	Screw . . . . .	22 415 18
70	Runner plate . . . . .	22 415 12
	Velvet-covered runner plate de luxe . . . . .	22 415 93
	41" (105 cm) velvet tape . . . . .	06 602 69
71	Mask plate . . . . .	22 416 89
72	Top sprocket with manual loop corrector . . . . .	22 443 40
73	Pad roller (see fig. 5) . . . . .	22 414 69
74	Mercury switch of automatic film-rupture device . . . . .	08 525 53
75	Automatic film-rupture device, complete (see sheet AA.E-fig. 13) . . . . .	type 8669
76	Drum shutter, complete . . . . .	22 413 65
77	Red window of shutter cover . . . . .	22 415 44
78	Centrifugal blade of drum shutter . . . . .	22 414 27
These parts are not shown in the illustration	Framing lamp fitting . . . . .	22 416 66
	Tension spring of centrifugal blade of drum shutter . . . . .	22 413 32
	Complete shutter of automatic film-rupture device (see sheet AA.E-fig. 13) . . . . .	22 443 30
	Glass window of projector door . . . . .	22 417 20
	Clamp for glass window . . . . .	22 417 39
	Projector door knob . . . . .	23 950 08
	Strip spring for door lock . . . . .	22 417 29
	Inching knob . . . . .	23 705 04
	Framing knob . . . . .	23 705 04
	Knob for lens focusing . . . . .	23 705 02
For the parts of the sound-head see sheet A.B.C-1		

§ 3. PARTS FOR THE DRIVING MECHANISM OF FP 5, FP 6 AND FP 7 PROJECTORS (fig. 3)

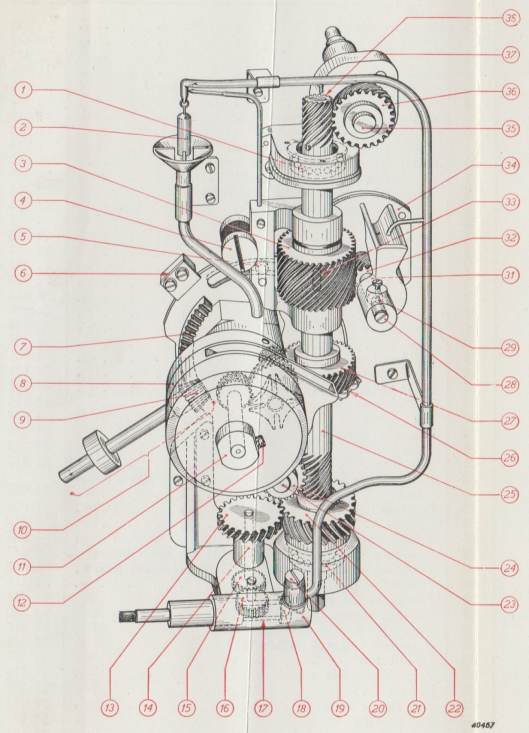

Fig. 3

Item No.	Description	Code number
1	Ball-bearing of main shaft . . . . .	89 181 07
2	Magnet . . . . .	22 443 70
3	Worm wheel . . . . .	22 444 40
4	Guide screw . . . . .	22 414 78
5	Steel ring in slot of framing disc . . . . .	22 415 17
6	Strip spring for pressure of framing disc . . . . .	22 414 70
7	Geared segment . . . . .	22 414 82
8	Intermittent unit complete with sprocket . . . . .	22 414 10
9	Conical gear wheel of framing shaft . . . . .	22 414 79
10	Framing shaft complete . . . . .	22 415 38
11	Nut . . . . .	22 414 20
12	Locking screw for nut "11" . . . . .	22 413 73
13	Gear wheel . . . . .	22 416 96
14	Driving shaft of oil pump . . . . .	22 417 04
15	Gear wheel . . . . .	22 414 87
16	Gear wheel . . . . .	22 414 87
17	Gauze of oil filter . . . . .	22 416 99
18	Magnet of oil filter . . . . .	22 414 44
19	Oil pump complete . . . . .	22 417 03
20	Hollow screw . . . . .	22 414 73
21	Ball-bearing of main shaft . . . . .	89 181 07
22	Worm wheel . . . . .	22 444 35
23	Spindle of bottom sprocket . . . . .	22 413 55
	Spindle of bottom sprocket complete with bearing . . . . .	22 417 07
24	Worm wheel of bottom sprocket . . . . .	22 413 60
25	Main shaft with key "33" . . . . .	22 741 14
	Main shaft, complete with bearing supports and gear wheels . . . . .	22 413 72
26	Strip spring for pressure of framing disc . . . . .	22 414 70
27	Worm wheel . . . . .	22 444 30
28	Pivot screw for adjusting shutter shaft . . . . .	22 414 47
29	Plug for locking pivot screw "28" . . . . .	22 413 88
31	Shutter shaft . . . . .	22 413 66
32	Worm wheel . . . . .	22 413 68
34	Drum-shutter shaft complete with bearing support and drive . . . . .	22 414 29
35	Top sprocket spindle . . . . .	22 413 54
36	Worm wheel of top sprocket . . . . .	22 413 60
37	Top sprocket spindle complete with bearing support and worm wheel . . . . .	22 413 52
38	Worm wheel . . . . .	22 414 34

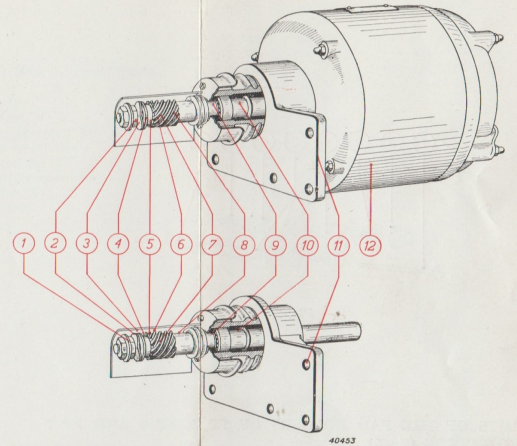

Fig. 4

§ 4. PARTS OF THE FLANGE MOTOR AND BELT PULLEY BEARING PLATE OF FP 5, FP 6 AND FP 7 PROJECTORS

Item No.	Description	Code number
1	Shaft . . . . .	22 415 33
2	Nut . . . . .	22 415 50
3	Ring . . . . .	22 415 53
4	Nut . . . . .	22 415 50
5	Spring ring . . . . .	22 415 51
6	Ring . . . . .	22 415 53
7	Ring . . . . .	22 443 91
8	Worm wheel . . . . .	22 415 54
9	Oil thrower . . . . .	22 443 90
10	Ball-bearing . . . . .	89 181 37
11	Gasket . . . . .	22 439 54
12	Flange motor . . . . .	08 620 81

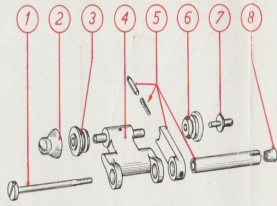
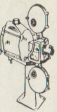

Fig. 5

§ 5. PARTS OF THE PAD ROLLERS OF FP 5, FP 6 AND FP 7 PROJECTORS (fig. 5)

Item No.	Description	Code number
1	Screw . . . . .	22 415 19
2	Ornamental screw . . . . .	22 415 23
3	Pressure roller . . . . .	22 265 88
4	Pad roller frame with pin . . . . .	22 465 01
5	Pin with arm and stop . . . . .	22 741 13
6	Pressure roller . . . . .	22 265 88
7	Screw . . . . .	22 465 05
8	Conical nut . . . . .	22 414 52

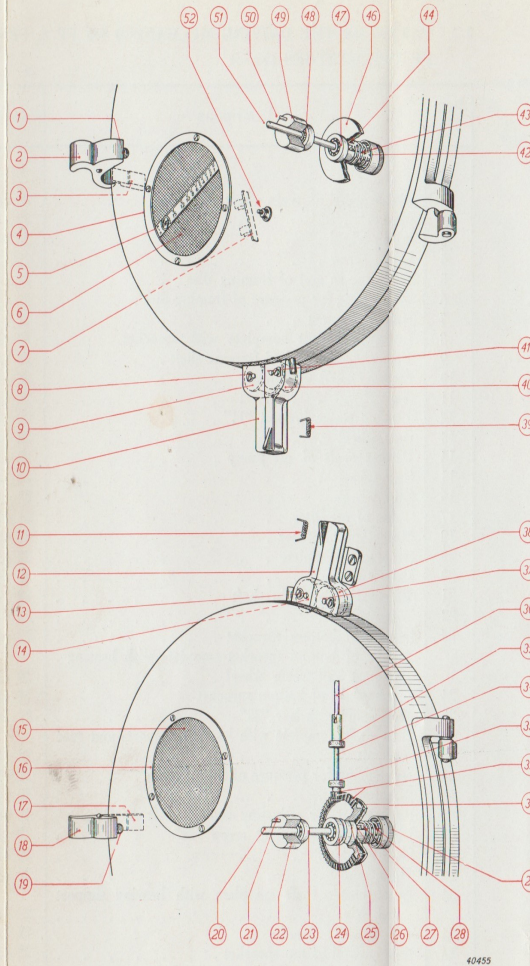

Fig. 6

§ 6. PARTS OF THE SPOOL BOXES AND SAFETY FIRE-TRAPS OF FP 5, FP 6 AND FP 7 PROJECTORS (fig. 6.)

Item No.	Description	Code number
1	Pressure spring . . . . .	22 452 69
2	Spool box lock . . . . .	22 438 38
3	Stud . . . . .	22 452 68
4	Ring . . . . .	22 415 59
5	Time scale (only for 3000 ft spool boxes) . . . . .	22 416 14
6	Gauze . . . . .	22 415 58
7	Fitting for pilot lamp . . . . .	22 416 66
8	Spindle of guide roller "9" . . . . .	22 416 47
9	Guide roller of safety fire-trap "10" . . . . .	22 416 30
10	Safety fire-trap of top spool box . . . . .	22 416 45
11	Torsion spring of fire-trap "9" . . . . .	22 430 66
12	Safety fire-trap of bottom spool box . . . . .	22 416 30
13	Spindle of guide roller "14" . . . . .	22 416 47
14	Guide roller of fire-trap "12" . . . . .	22 416 45
15	Gauze . . . . .	22 415 58
16	Ring . . . . .	22 415 59
17	Stud . . . . .	22 452 68
18	Spool box lock . . . . .	22 438 38
19	Pressure spring . . . . .	22 452 69
20	Spindle . . . . .	22 415 85
21	Carrier pin . . . . .	22 416 44
22	Disc . . . . .	22 415 69
23	Ball-bearing . . . . .	89 181 04
24	Ball-bearing . . . . .	89 181 04
25	Ball-bearing . . . . .	89 181 04
26	Ball-bearing . . . . .	89 181 04
27	Pin . . . . .	22 416 76
28	Pressure spring . . . . .	22 415 84
29	Milled nut . . . . .	22 415 71
31	Felt disc . . . . .	22 415 78
32	Gear wheels for driving the spindle of bottom spool box . . . . .	22 741 20
33	Ball-bearing . . . . .	22 926 30
34	Spindle . . . . .	22 416 41
35	Ball-bearing . . . . .	22 926 30
36	Coupling spindle for 3000 ft (900 m) spool boxes . . . . .	22 415 94
	Coupling spindle for 4000 ft (1300 m) spool boxes . . . . .	22 416 54
37	Spindle of flange roller "33" . . . . .	22 416 47
38	Flange roller of fire-trap "12" . . . . .	22 416 46
39	Torsion spring of fire-trap "10" . . . . .	22 430 66
40	Flange roller of fire-trap "10" . . . . .	22 416 46
41	Spindle of flange roller "40" . . . . .	22 416 47
42	Milled nut . . . . .	22 415 71
43	Pressure spring . . . . .	22 415 84
44	Pin . . . . .	22 416 76
46	Felt disc . . . . .	22 415 78
47	Ball-bearing . . . . .	89 181 04
48	Ball-bearing . . . . .	89 181 04
49	Disc . . . . .	22 415 69
50	Carrier pin . . . . .	22 416 44
51	Spindle . . . . .	22 415 61
52	Milled screw . . . . .	07 743 08

## VII ORDERING NUMBERS OF THE PRINCIPAL SPARE PARTS OF TYPE 3837 SOUND-HEAD

AB.G-1  
1.11.47

When ordering spare parts, please always mention:

1. the type and model number of the sound-head;
2. the serial number of the sound-head.

These numbers are indicated on the plate at the front of the soundhead, underneath the sound-drum.

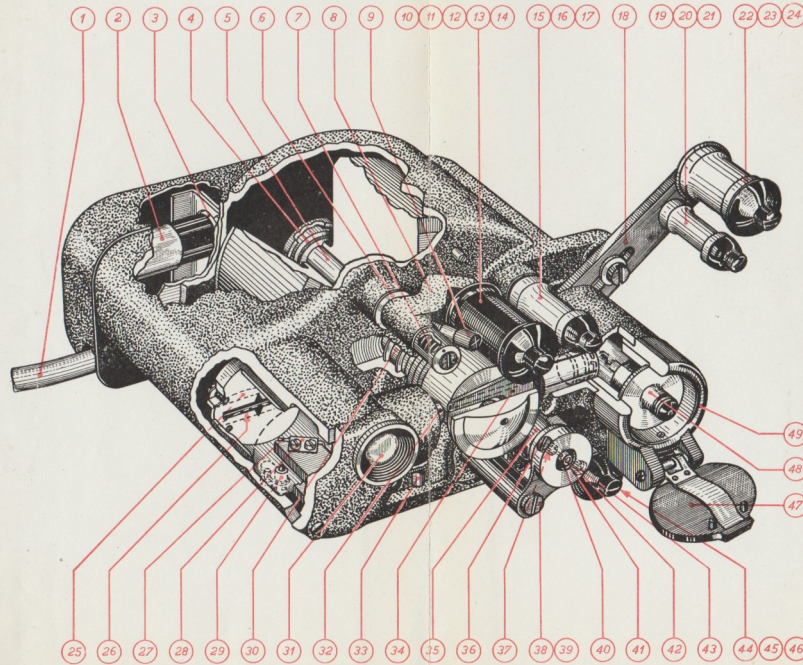

Fig. 1

Item No.	Description	Code or type number			
		3837/00 3837/01	3837/30 3837/31	3837/10 3837/11	3837/20 3837/21
1	photo-cell cable, length 1.20 m	8615/00	8615/00	8615/00	8615/00
	" " " " 2.50 m	8615/05	8615/05	8615/05	8615/05
	" " " " 3.00 m	8615/10	8615/10	8615/10	8615/10
	" " " " 4.00 m	8615/20	8615/20	8615/20	8615/20
2	photo-cell	8615/30	8615/30	8615/30	8615/30
3	photo-cell holder	3533	3533	3533	3533
4	ball-bearing of sound shaft	25 161 32	25 161 32	25 161 32	25 161 32
5	sound shaft	89 181 06	89 181 06	89 181 06	89 181 06
6	steel washer	22 439 26	22 466 48	22 439 26	22 466 48
7	spiral spring for pressure roller "10"	22 414 99	22 414 99	22 414 99	22 414 99
8	lever with pressure roller "10"	22 413 24	22 413 24	22 413 25	22 413 25
9	adjusting screw with milled knob	22 439 08	22 439 08	22 466 31	22 466 31
10	pressure roller	22 439 10	22 439 10	22 439 10	22 439 10
11	ball-bearing of pressure roller "10"	22 443 11	22 443 11	22 443 11	22 443 11
12	ball-bearing of pressure roller "10"	89 180 99	89 180 99	89 180 99	89 180 99
13	shaft of pressure roller "10"	89 180 99	89 180 99	89 180 99	89 180 99
14	ornamental screw of pressure roller "10"	22 439 12	22 439 12	22 439 12	22 439 12
15	guide roller	22 439 53	22 439 53	22 439 53	22 439 53
16	shaft of guide roller "15"	22 439 07	22 439 07	22 439 07	22 439 07
17	ornamental screw of guide roller "15"	22 443 12	22 443 12	22 443 12	22 443 12
18	silencer	22 415 23	22 415 23	22 415 23	22 415 23
19	guide roller	8317/00	8317/00	8317/10	8317/10
20	shaft of guide roller "19"	22 439 07	22 439 07	22 439 07	22 439 07
21	ornamental screw of guide roller "19"	22 443 15	22 443 15	22 443 15	22 443 15
22	guide roller	22 415 23	22 415 23	22 415 23	22 415 23
23	shaft of guide roller "22"	22 265 95	22 265 95	22 265 95	22 265 95
24	ornamental screw of guide roller "22"	22 443 15	22 443 15	22 443 15	22 443 15
		22 439 53	22 439 53	22 439 53	22 439 53

\*) Exclusively for models Nos. /00, /10, /20 and /30.

Item No.	Description	Code or type number			
		3837/00 3837/01	3837/30 3837/31	3837/10 3837/11	3837/20 3837/21
25	condenser lens for normal track reproduction 1)	22 439 36	22 439 36	22 439 36	22 439 36
	or condenser lens for "dual-track" reproduction 2)	22 439 75	22 439 75	22 439 75	22 439 75
26	screen with slit	22 439 35	22 439 35	22 439 35	22 439 35
27	mirror	22 439 21	22 439 21	22 466 34	22 466 34
28	plate spring for fixing mirror "27"	22 439 50	22 439 50	22 439 50	22 439 50
29	adjusting pin	22 439 23	22 439 23	22 439 23	22 439 23
30	ball-bearing of the sound shaft	89 181 06	89 181 06	89 181 06	89 181 06
31	observation window	22 439 17	22 439 17	22 439 17	22 439 17
32	microscope lens	22 439 32	22 439 32	22 439 32	22 439 32
33	adjusting pin	22 439 23	22 439 23	22 439 23	22 439 23
34	light-focusing system, complete with glass rod and lenses	22 439 27	22 439 27	22 439 27	22 439 27
44	guide roller	22 265 95	22 265 95	22 265 95	22 265 95
45	shaft of guide roller "44"	22 443 12	22 443 12	22 443 12	22 443 12
46	ornamental screw of guide roller "44"	22 439 53	22 439 53	22 439 53	22 439 53
47	cover with contact spring	22 438 83	22 438 83	22 438 83	22 438 83
48	exciter lamp 6 V, 1.48 A	3874	3874	3874	3874
	or exciter lamp 5 V, 4.0 A	7251 C	7251 C	7251 C	7251 C
49	exciter lamp holder, complete	23 705 06	23 705 06	23 705 06	23 705 06

\*) Exclusively for models Nos. /01, /11, /21 and /31.



3837

# AB SOUND-HEAD TYPE 3837

## CONTENTS

I	General description . . . . .	AB.A
II	Constructional details. . . . .	AB.B
III	Applications . . . . .	AB.C
	§ 1. Normal projection with FP 5 and FP 6 projectors . . . . .	1
	§ 2. Normal projection as an incorporated sound-head of the FP 7 projector . . . . .	1
	§ 3. Rear projection with FP 5 and FP 6 projectors . . . . .	1
	§ 4. Universal model for adaptation to projectors of various makes . . . . .	1
IV	Adjustment and checking. . . . .	AA.D
	§ 1. The lateral adjustment of the sound-track . . . . .	1
	§ 2. The adjustment of the pressure roller . . . . .	2
	§ 3. Checking the smooth running of the sound-drum and of the pressure roller . . . . .	4
	§ 4. The adjustment of the optical system . . . . .	5
	§ 5. Checking the uniform light distribution on the observation screen . . . . .	6
V	Removing and replacing the various parts . . . . .	AB.E
	§ 1. The pressure roller and the guide rollers . . . . .	1
	§ 2. The sound-drum and the flywheel . . . . .	2
	§ 3. The optical parts . . . . .	3
	§ 4. The photocell housing with photocell cable . . . . .	4
	§ 5. The holder of the exciter lamp . . . . .	5
VI	Proposal for stock . . . . .	AB.F
	§ 1. Proposal for a small stock of spare parts for type 3837 sound-head . . . . .	1
	§ 2. Proposal for a larger stock of spare parts for type 3837 sound-head . . . . .	1
VII	Order numbers of the principal spare parts of type 3837 sound-head . . . . .	AB.G



3837



## I GENERAL DESCRIPTION

When designing the new type 3837 sound-head (fig. 1) Philips considered that, besides good reproduction and easy adaptability to the various types of projectors, the apparatus would have to be suitable for future developments in recording and reproduction technique.

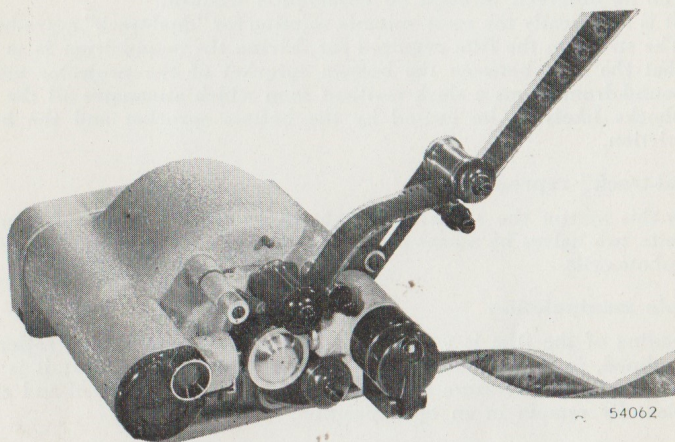

In this connection we are thinking of "stereophonic" and "push-pull" reproduction, both known under the name of "dual-track" reproduction, which, as soon as introduced in practice, will greatly improve sound quality. Philips have taken care that a slight modification permits of adapting type 3837 sound-head to these two systems. Moreover, this sound-head is provided with a separate device for checking the adjustment of the sound-track with respect to the scanning slit.

This elegant sound-head has a modern shape. Its appearance is further enhanced by the fact that the cables for the exciter lamp and the photo-cell are inside the sound-head and hence invisible from outside.

The principal features of the sound-head are:

### 1. Excellent sound reproduction

Type 3837 sound-head is provided with a rotary sound-drum which is driven by the film. To obtain a sufficient contact between the film and the sound-drum, guide rollers have been provided which ensure that the film lies over a large angle on the periphery of the sound-drum. The starting time of the sound-drum is only about 3.5 seconds.

### 2. Effective sound scanning

With the aid of a condenser system and a glass rod a light spot of great uniformity and brightness is projected onto the sound-track of the film. The strongly illuminated sound-track is enlarged about 12.5 times by



3837



3837

means of a microscope lens and projected onto a screen with slit. Directly behind this slit is a condenser lens which concentrates the light on a highly sensitive photo-cell.

The advantages of this system are:

- It possesses a very uniform light distribution, as the glass rod projects the light diffusely onto the film.
- It guarantees a great sensitivity of the sound scanning system.
- It offers the possibility of checking accurately the lateral displacement and the correct image of the sound-track as well as the uniformity of light distribution. The 12.5 times enlarged image of the sound-track can be observed through an observation window.
- It is technically the most suitable solution for "dual-track" reproduction.
- The stress on the film required for driving the sound-drum is so small that the film between the bottom sprocket of the projector and the sound-drum forms a slack resilient loop which attenuates all the small shocks likely to be caused by the bottom sprocket and the bottom friction.

### 3. "Dual-track" reproduction

With this system the scanning light-beam is divided directly behind the slit into two halves by means of two lenses; each half falls onto one of the two photo-cells.

### 4. Simple manipulation

Threading of the film is very simple. The knobs of the guide rollers are streamlined, so that the film slides easily between the rollers; it is sufficient to open the pressure roller. This roller is spring-loaded and cannot accidentally remain in an open position.

### 5. Shifting of the film with respect to the scanning slit

As in practice the sound-track is not printed always at the correct place, it must be possible to shift the film and the scanning slit with respect to each other. This is effected by means of an adjusting screw with knurled knob, by which the pressure roller and consequently also the film can be shifted in a lateral direction with respect to the sound-drum.

This possibility of adjustment is of the greatest importance, especially with "dual-track" reproduction.

### 6. Accurate checking of the lateral displacement of the sound-track

Through an observation window the above-mentioned displacement is visible on a screen provided in the path of the light-beam.

### 7. Instant replacement of the pre-focused exciter lamp and of the photo-cell

The exciter lamp can be removed after opening a lid. This lamp is provided with a centering flange so that it is automatically focused.

The photo-cell can be replaced after removing the cap at the rear; this cap is fixed with only one knurled nut.

### 8. Easy adaptation to practically any projector

The diameter of the sound-drum is only small, so that the dimensions of the flywheel and consequently also those of the entire sound-head could be kept so small that the apparatus can be adapted to practically all makes of projectors.

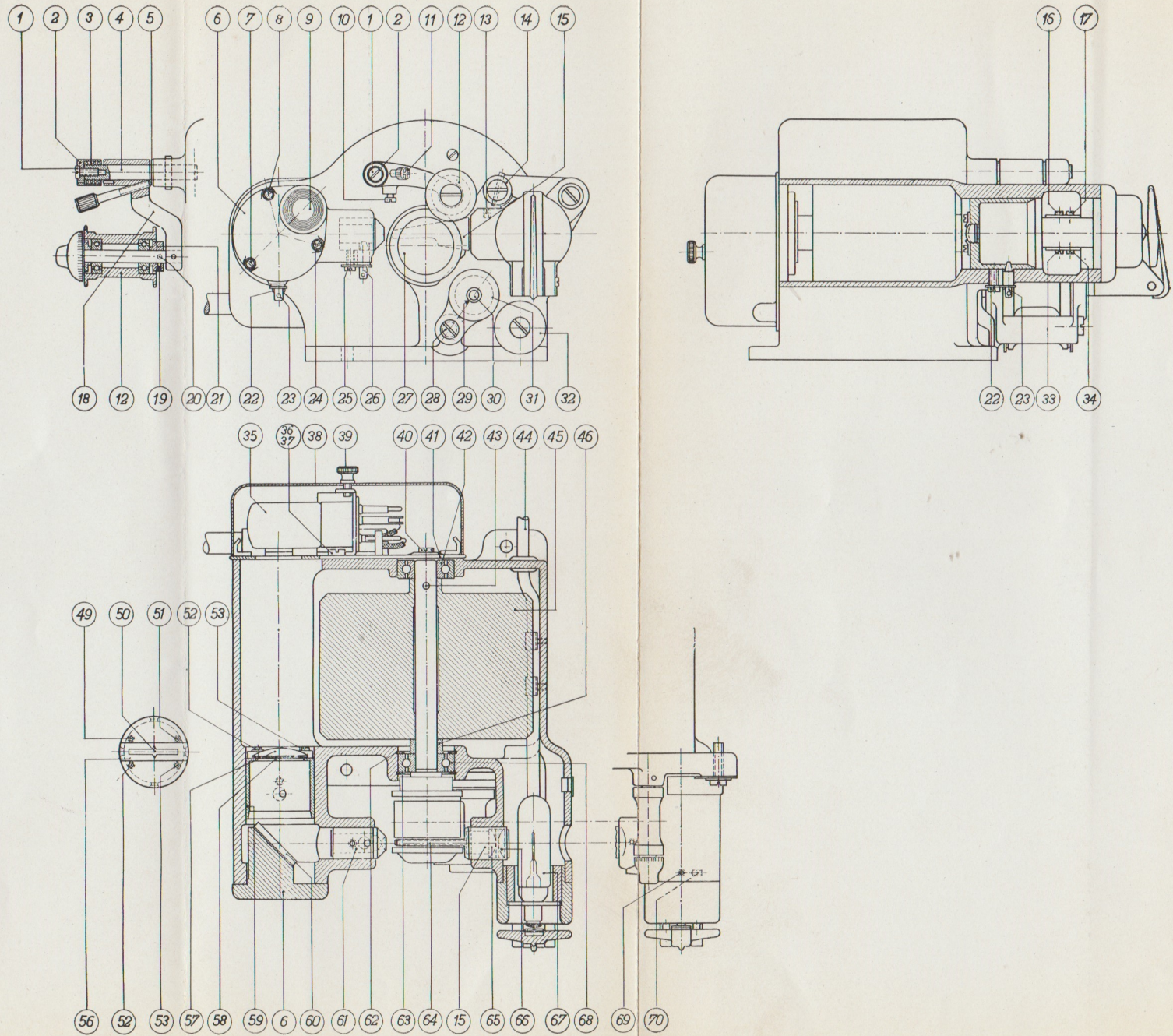

Fig. 2

## II CONSTRUCTIONAL DETAILS

The principal dimensions are indicated in fig. 1. The sound-head (fig. 2) is provided with a rotary sound-drum "27" with flywheel "45". Pressure roller "12" which, like the sound-drum, runs on high-precision ball-bearings, ensures a perfect contact between the sound-drum and the film, so that the film forms one entity with the sound-drum — and consequently also with the flywheel — at the place where the sound is scanned. The pressure roller, which has to be lifted for threading the film, cannot remain in its open position; therefore it is not possible to forget to close it. After having passed the sound-drum the film runs over guide roller "32". The optical system (see also figs 3 and 4) for scanning the sound consists of two parts, viz.:

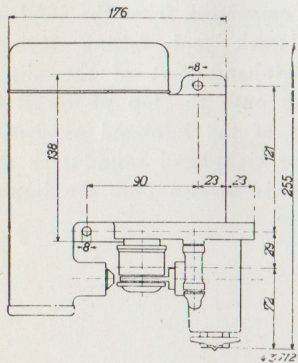
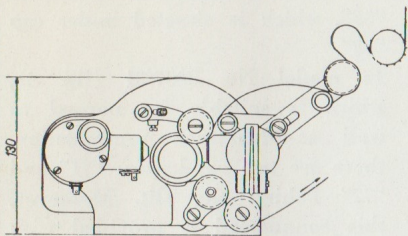

Fig. 1

lamp "67", two condenser lenses "65" and "66" and the glass rod "64". It projects a light spot of great brightness and uniformity onto the sound-track.

2. The microscope lens "61" specially corrected for the projection of the sound-track, projecting an approximately 12.5 times enlarged image of the sound-track onto the white screen "66", via mirror "60"; this image can be checked through observation window "9". In the middle of the

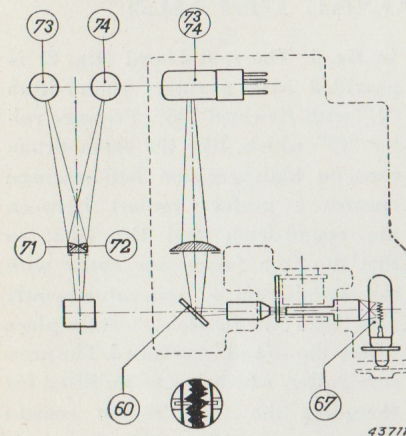
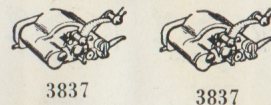

Fig. 4.

In the same way the light emanating from the right-hand sound-track and passing through the right-hand part of the slit is thrown onto the bottom photocell by means of the right-hand condenser.

1. The light-focusing system, which consists of the pre-focused exciter

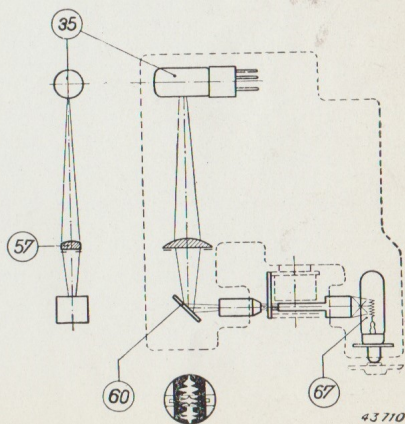

Fig. 3

### III APPLICATIONS

§ 1. NORMAL PROJECTION WITH FP 5 AND FP 6 PROJECTORS

Type 3837 sound-head is readily suitable for normal projection with FP 5 and FP 6 projectors, viz. model No. 3837/00 for normal sound-track reproduction and model No. 3837/01 for "dual-track" reproduction.

§ 2. NORMAL PROJECTION AS AN INCORPORATED SOUND-HEAD OF THE FP 7 PROJECTOR

The sound-head which is incorporated in the FP 7 projector is of exactly the same construction as type 3837 sound-head and can be supplied for normal track as well as for "dual-track" reproduction. The type number of the FP 7 projector with incorporated sound-head for normal reproduction is No. 8670, that of the projector with incorporated sound-head for "dual-track" reproduction No. 8672.

§ 3. REAR PROJECTION WITH FP 5 AND FP 6 PROJECTORS

A special model of type 3837 sound-head can be supplied for rear projection with FP 5 and FP 6 projectors, viz. type 3837/30 for normal track and type 3837/31 for "dual-track" reproduction.

§ 4. UNIVERSAL MODEL FOR ADAPTATION TO PROJECTORS OF VARIOUS MAKES

Type 3837 sound-head, complete with silencer, can be supplied for adaptation to a large number of projectors of foreign make. A choice can be made from the following models.



3837



3837

466 62

Type of projector	Front or rear projection	Position of the sound-head with respect to the projector	Type No.	Model No.		--- = centre line of film ... = centre line of sound-track
				Normal repr.	"Dual-track" repr.	
right-hand left-hand	front rear	behind before	3837 3837	00 00	01 01	
right-hand left-hand	front rear	before behind	3837 3837	10 10	11 11	
right-hand left-hand	rear front	before behind	3837 3837	20 20	21 21	
right-hand left-hand	rear front	behind before	3837 3837	30 30	31 31	

## IV ADJUSTMENT AND CHECKING

(See page AB.B, fig. 2)

### § 1. THE LATERAL ADJUSTMENT OF THE SOUND-TRACK

For obtaining the correct position of the film, it can be shifted in a lateral position, during the performance, by turning adjusting screw "11" with milled knob, which is marked with a cross. For this purpose the ends and the middle of the scanning slit are distinctly marked on the screen. This adjustment is very important for films of which the sound-track has not been printed at the correct place, and especially for "dual-track" recordings where two separate sound-tracks are situated beside each other.

For "dual-track" reproduction the adjustment must be such that the centre mark is situated exactly in the middle between the two sound-tracks. If necessary, the loosening or fastening of screw "11" can be made easier or harder by turning screw "10", thereby pressing a small leather piece onto the thread of screw "11".



3837



3837

### § 2. THE ADJUSTMENT OF THE PRESSURE ROLLER

For perfect working of the pressure roller it is necessary to make two adjustments, viz.:

**adjustment of the pressure of the roller on the sound-drum and adjustment of the correct position of the roller with respect to the sound-drum.**

#### 1. Adjustment of the pressure of the roller on the sound-drum

The time it takes the sound-drum to attain its normal number of revolutions after starting is determined by the pressure of roller "12" on the sound-drum "27". This time is  $3\frac{1}{2}$  seconds for a pressure of 1.1—1.3 lbs (500—600 g). The pressure can be adjusted by turning milled ring "2", after loosening screw "1"; it must not exceed 1.3 lbs (600 g) and can be measured by means of a spring balance, the hook of which is fastened to the pressure roller. If the pressure is too great, the film will be damaged during starting.

#### 2. Adjustment of the correct position of the roller with respect to the sound-drum

If the axis of the pressure roller were exactly parallel to that of the sound-drum, the running film would have a lateral movement between the flanges of the pressure roller. In order to prevent this, the axis of the pressure roller is *not* parallel to that of the sound-drum but such that, reckoned from the parallel position and seen from the operating side of the projector, the end of the pressure roller shaft protruding at the front is situated  $0.00275''$  (0.07 mm) higher and  $0.004''$  (0.1 mm) to the right.<sup>1)</sup>

Consequently the film is always touching the front flange of the pressure roller and all lateral movement, including that at the place of sound scanning, is avoided. This is of the utmost importance, especially for "dual-track" reproduction.

The correct position of the pressure roller is adjusted in the factory before the sound-heads are delivered.

The adjustment is made and checked as follows:

#### a. Adjustment and checking of the oblique position, $0.00275''$ (0.07 mm) upwards<sup>1)</sup>

Carefully bend slightly the shaft of the pressure roller with the aid of a brass tube with an inner diameter of  $0.23622''$  (6 mm). This tube has to be pushed over the entire length of the shaft. The correct position is checked by interposing a piece of paper — thickness  $0.00275''$  (0.07 mm) — between the running surfaces of the pressure roller and the sound-drum. It must be possible to move the paper strip freely, whereas two such strips should be held tightly between the pressure roller and the sound-drum.

#### b. Adjustment and checking of the oblique position $0.004''$ (0.1 mm) to the right<sup>1)</sup>

The oblique position to the right is also obtained by bending the shaft of the pressure roller with the aid of the brass tube. The correct position is checked by removing the pressure roller and roller "14" and measuring the distance over their spindles with a sliding rule.

<sup>1)</sup> This applies to the normal right-hand sound-heads Nos. 3837/00 and /01, as well as to FP 7 projectors.

**AB. D-3**

1.11.47

If for instance at the rear a distance of 1.328" is measured, then the distance at the front must be 1.328" — 0.004".  
Of course these adjustments should only be made by technicians.

The oblique position for the other models is indicated in the table below:

Model No.	Oblique position
3837/00 and /01	0.00275" upwards, 0.004" to the right
3837/10 and /11	0.00275" " " 0.004" " " left
3837/20 and /21	0.00275" downwards, 0.004" " " right
3837/30 and /31	0.00275" " " 0.004" " " left



3837



3837

**AB. D-4**

1.11.47

### § 3. CHECKING THE SMOOTH RUNNING OF THE SOUND-DRUM AND OF THE PRESSURE ROLLER

After the film has passed through the apparatus, the sound-drum and the pressure roller should run for at least 40 seconds and at the most 80 seconds. If they come to a standstill earlier, the sound-drum and/or the pressure roller are not running sufficiently smoothly, which may cause hoarseness in the sound. It must then be ascertained whether it is the sound-drum or the pressure roller that is running too heavily.

1. **The sound-drum with flywheel** is checked by repeating the above test, but with the pressure roller lifted from the sound-drum. If the sound-drum continues to run longer than 2 minutes it is in order and the fault lies in a heavily running pressure roller. If, on the other hand, the sound-drum comes to a standstill within 2 minutes this may be caused by:
  - a. the flywheel being braked by cable "44" of the exciter lamp, due to this cable not being drawn sufficiently tight up against the inner wall of the sound-head housing;
  - b. dirt having accumulated between the groove in the sound-drum and the optical system for illumination;
  - c. a clogged up ball-bearing. For cleaning see page ABE.4.
2. **Heavy running of the pressure roller** may be caused by:
  - a. a clogged up ball-bearing. For removing, cleaning and readjusting see page ABE.1;
  - b. the axial play being too small. To ensure light running, the pressure roller must have a slight but perceptible axial play, which can be adjusted by shifting ring "21", after loosening the two screws "19" and "20".

## § 4. THE ADJUSTMENT OF THE OPTICAL SYSTEM

The optical system is adjusted by means of two fine adjustments, viz.:

- a. the focusing device of the microscope lens;
- b. the adjustment of the slit so that it is exactly perpendicular to the direction of movement of the film, as visible on the observation screen.

Both adjustments are made by turning the eccentric adjusting pins "26" and "23", which are secured with screws "25" and "22".

In the factory these adjustments are made by running a special frequency film, whilst a substitute resistance and an A.C. voltmeter, which is independent of the frequency, are connected to the output terminals of the amplifier. The two adjustments are made independently of each other, until a maximum reading on the voltmeter is obtained at a frequency of 6000 and 9000 c/s. When adjusting the tube "59" with pin "23" care has to be taken to see that a maximum reading is obtained in two positions.

For good working it is important to choose the position in which the tube with slit plate is as close to the mirror as possible.

Of course, the optical system must be adjusted exclusively by Philips technicians and only when absolutely necessary. This is the case:

1. after replacement of the tube "59" or part of it;
2. after replacement or removal of mirror holder "6" or mirror "60";
3. after replacement of microscope lens "61".

If necessary, the above adjustments can also be made by ear. When doing this, while the film is running,

- a. the focusing of the microscope lens should be such that the film hiss is as strong as possible; it is recommendable to use for this purpose a slightly scratched film;
- b. the tube "59" should be adjusted so that with speech reproduction the sibilants are as strong as possible; for this purpose it is best to use a good film with speech;
- c. the adjustment under a. should be repeated.

However, such an emergency adjustment has to be revised as soon as possible according to the correct method by a Philips technician.



3837



3837

## § 5. CHECKING THE UNIFORM LIGHT DISTRIBUTION ON THE OBSERVATION SCREEN

A uniform light spot must be visible on the observation screen when the exciter lamp is burning and no film is threaded in the apparatus. Dark spots are mostly caused by film dirt deposited at the end of the glass rod in the holder of the light-focusing system. This film dirt must be removed but only with a soft brush. If dark spots are then still visible, remove the holder of the light-focusing system (see page AB.E-3) and examine the front surface of the glass rod under a magnifying glass. If this surface is found to be damaged, the entire holder of the light-focusing system, Code No. 22 439 27, which contains the glass rod and two condenser lenses, must be replaced.

When re-mounting see that the slit in the sound-drum is perfectly clean. Moreover, care should be taken that adjusting screw "13" goes into the groove in the holder provided for this purpose. Then make the distance between the film and the front of the holder exactly 0.02" (0.5mm). This measure must be strictly maintained; if it is less, the film might be damaged.

After replacing the holder of the light-focusing system, the microscope lens "61" and tube "59" need not be re-adjusted.

If, after the optical system for illumination has been thoroughly cleaned and well adjusted, there are still dark spots visible, then the microscope lens "61" and mirror "60" have to be removed and examined.

When removing the mirror, take care not to touch its surface in any way, as this might damage the mirror so badly as to make it useless.

One of the microscope lenses may also be damaged.

The surface of the mirror must of course be perfectly clean.

It is absolutely necessary to re-adjust the optical system (see page AB.D-5) after the microscope lens and/or the mirror have been removed.

## V REMOVING AND REPLACING THE VARIOUS PARTS

### § 1. THE PRESSURE ROLLER AND THE GUIDE ROLLERS

#### 1. Pressure roller "12"

This roller can be removed after loosening the ornamental screw. When drawing the pressure roller from its shaft be careful with the two ball-bearings, which come off with this roller. If necessary flush out these ball-bearings with clean petrol and then lubricate with a few drops of cardan oil.

#### 2. Pressure roller "12" complete with lever

After screw "1" has been unscrewed, it is possible to remove successively milled ring "2", spiral spring "3" and lever "18" with pressure roller "12" and steel washer "15".

When replacing these parts, lubricate the fulcrum point of the lever with cardan oil. Moreover, re-adjust the pressure of the pressure roller on the film to 500—600 g (see page AB.D-2).

#### 3. Small guide roller "14" and large guide roller "32"

These rollers can be drawn off their spindles after loosening the respective ornamental screws.



3837



3837

### § 2. THE SOUND-DRUM AND THE FLYWHEEL

To remove this part the entire sound-head has to be taken from the inclinable mounting table. Then remove the holder of the optical system "15" and the entire photo-cell housing "41" and put a piece of wood between the lever of the pressure roller and the casting of the sound-head, so that later on, when removing the sound-drum, it is not hampered by the spring-loaded pressure roller. The conical pin "43" is then **very carefully** tapped out of the flywheel and the shaft. After that the sound-head is held in a bench-vice with the sound-drum downwards, after which the sound-drum can be pulled carefully downwards. Then flywheel "45", washer "46" and the top ball-bearing "42" can be removed.

The bottom ball-bearing "68" can be taken out **after removing one of the spring rings "62" or "63"** between which this bearing is held. The simplest way to remove and re-fit the spring rings is to use round-nosed pliers with thin jaws.

Mounting is done in the reverse order; it is very important that the sound-head should again be held in a bench-vice with its shaft vertical. Before mounting, the ball-bearings have to be rinsed in very clean and dust-free spindle oil; this oil remains in the ball-bearings as lubricating oil.

Mounting has to be done in a dust-free room.

The correct mounting of sound-drum and flywheel can be tested by turning the sound-shaft while holding the entire sound-head in both hands in its normal position. No shocks whatsoever should then be felt. For testing the smooth running of the sound-drum see page AB.D-4.

§ 3. THE OPTICAL PARTS

The holder for the light-focusing system "15" can be pushed backwards after removing exciter lamp "67" and loosening screw "13". One is strongly advised against taking the holder itself to pieces as special tools are required for this purpose (for mounting and adjusting see page AB.D-6).

The mirror holder with observation window "6" can be removed after unscrewing the three screws "7", "8" and "24". The observation window "9" can be unscrewed by hand. If the mirror holder is made of "Philite", this window is fixed by means of a resilient ring. Mirror "60" is removed by unscrewing the two screws "16" and "17" or "33" and "34".

Never touch the mirror surface as this might irreparably damage it.

Microscope lens "61" and tube "59" with slit plate can be removed after taking out the mirror holder, loosening screws "25" or "22" and removing adjusting pin "26" or "23" respectively. Of course this is only done in case of absolute necessity, as after re-mounting the adjustments mentioned on page AB.D-6 have to be made again.

When mounting, no grease or oil should be used, so as to prevent the lenses from becoming greasy in course of time.

Slit-plate "50" and lens "57" can be removed from the tube "59" after unscrewing the two screws "49" and "52" or "51" and "53". After re-mounting, see with a microscope or a magnifying glass whether slit "50" is absolutely free from dust and dirt. Of course, lens "57" should be carefully cleaned.



3837

3837

§ 4. THE PHOTOCELL HOUSING WITH PHOTOCELL CABLE

The cap "38" and the photocell can be removed after unscrewing the milled nut "39".

The photocell housing can be removed after unscrewing the three screws "36", "37" and "40".

Care should be taken that no dust can penetrate into the rear ball-bearing while the assembly is removed.

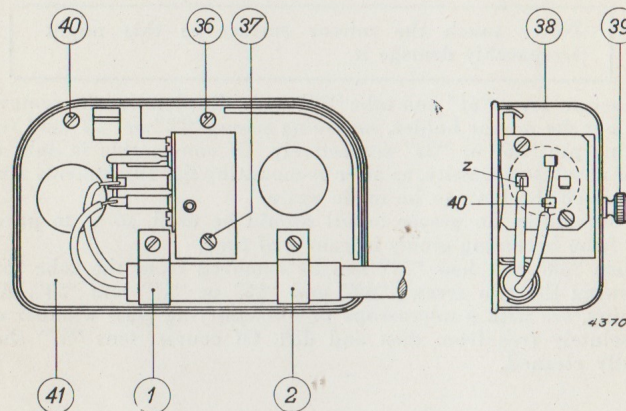

Fig. 1

The photocell cable is fixed to the photocell housing with two braces "1" and "2".

The connections to the photocell holder have to be made as indicated in fig. 1, using resin as a flux; fluxes which are not free from acid cause a crackling sound.

The wire marked "Z" in fig. 1 is provided with a red rubber collar, the wire marked "40" with a black one.



AB.E-5

E.11.47

§ 5. THE HOLDER OF THE EXCITER LAMP

The holder of the exciter lamp can be removed after unscrewing the two screws "69" and "70" and disconnecting the electrical connections at the bottom of the holder.



3837



AB.F-1

L.11.47

## VI PROPOSAL FOR STOCK

It is recommended to keep the following spare parts in stock in every cinema, so that in case of need any damaged or worn out parts can be replaced immediately.

Below suggestions are given for a small and a larger stock.

### § 1. PROPOSAL FOR A SMALL STOCK OF SPARE PARTS FOR TYPE 3837 SOUND-HEAD



3837

Quantity	Description	Code or type number
4	exciter lamps . . . . .	3874 (abt. 6 V, 1.48 A) or 7251 C (abt. 5 V, 4.0 A)
1	photocell . . . . .	3533

### § 2. PROPOSAL FOR A LARGER STOCK OF SPARE PARTS FOR TYPE 3837 SOUND-HEAD

In addition to the parts listed above:

Quantity	Description	Code or type number
1	light-focusing system, complete with glass rod and lenses . . . . .	22 439 27
1	mirror . . . . .	22 439 21
1	microscope lens . . . . .	22 439 32
1	spiral spring for pressure roller . . . . .	22 413 24

