

DIRECTIONS for INSTALLATION  
of AMPLIFIERS EL 5373 and EL 5374  
for 70/35-mm EQUIPMENT





DIRECTIONS for INSTALLATION  
of AMPLIFIERS EL 5373 and EL 5374  
for 70/35-mm EQUIPMENT

**FIXING TO THE WALL**

This is the same for the pre-amplifier and  
for the output-amplifier rack;  
only the place of the fixing holes is different.

All the racks have a width of 378 mm (1'3") and a depth of 400 mm (1'3<sup>3</sup>/<sub>4</sub>").  
The height of the racks varies:

Types of racks	Height		Centre distance (H) between upper and lower fixing bolts	
EL 5373/20.../25	3' 2 <sup>5</sup> / <sub>8</sub> "	980 mm	3' 1 <sup>3</sup> / <sub>8</sub> "	950 mm
EL 5373/30.../35	3' 8"	1120 mm	3' 6 <sup>7</sup> / <sub>8</sub> "	1090 mm
EL 5374/00	2' 10 <sup>1</sup> / <sub>2</sub> "	875 mm	2' 9 <sup>1</sup> / <sub>4</sub> "	845 mm
EL 5374/10	3' 4"	1015 mm	3' 2 <sup>3</sup> / <sub>4</sub> "	985 mm

- . Fix in the wall for each rack the four <sup>3</sup>/<sub>8</sub>" bolts supplied with the racks as indicated in fig. 2.
- . Take all the plug-in units out of both racks.
- . Open the lock by means of which the rack is clamped against the mounting frame and open the rear of the rack.
- . Lift rack and frame together and fix the frame by means of the four bolts against the wall.
- . Insert all the units again as indicated in the drawing supplied with the equipment.

**Note:** The distance between the two racks must be at least 50 cm (1'8").

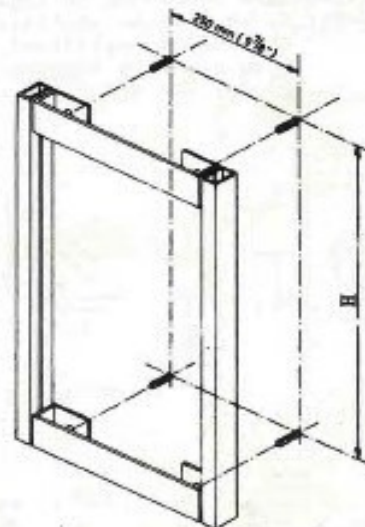
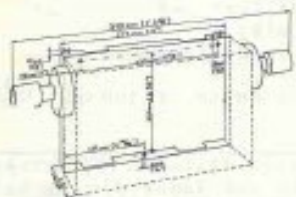

Fig. 2





**Fixing of volume control EL 5463 (fig. 3)**



In the chassis of this volume control there are three  $\frac{1}{4}$ " (6 mm) fixing holes. If the volume control has to be provided with an extension rod, mount it according to fig. 4. For aligning the rod, loosen screw "1" and shift disc "2" together with disc "3". For fixing bracket "4" to the wall two wedge bolts are supplied with the volume control.

Fig. 3

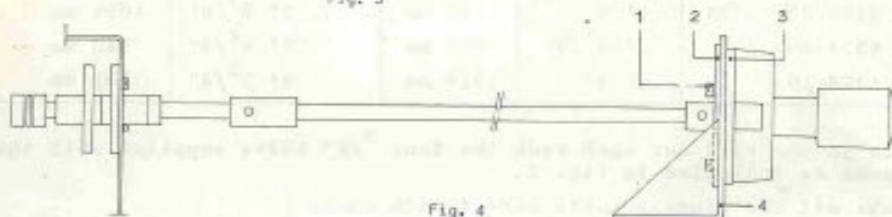

Fig. 4

**Mains connection**

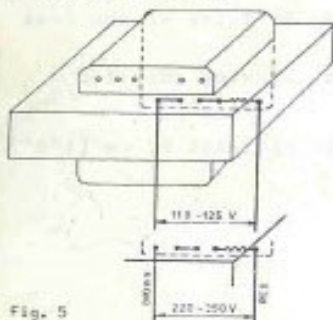

Fig. 5

Normally the equipment is supplied for connection to 220 V  $\sim$ . For connection to 110-125 V (tropics 100-120 V) or 220-250 V (tropics 200-240 V) the connections of the transformer of the power-supply unit have to be changed as indicated in fig. 5. Moreover, the connections of the supply transformers of all the output amplifiers have to be changed according to fig. 6a or 6b.

**Note:** As no voltage stabilisation is used in the output amplifiers, the transformers have separate tappings for 110 and 125 V or for 220 and 250 V, respectively.

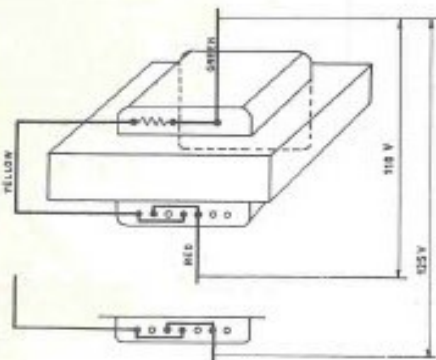

Fig. 6a

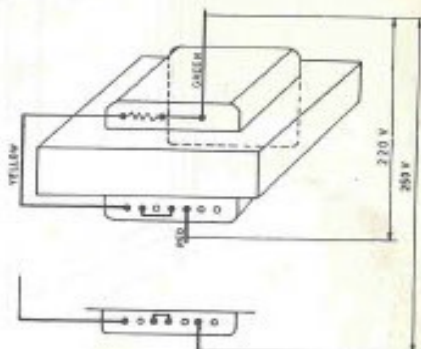

Fig. 6b



**Exciter-lamp supply**

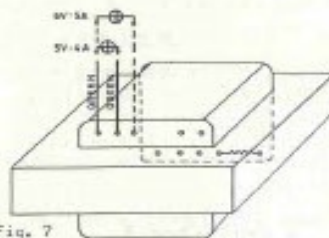

Fig. 7

The power-supply unit can be made suitable for exciter lamps of 5 V/4 A or 6 V/5 A or 9 V/4 A.

If not indicated otherwise in the order, the equipment is delivered for lamps of 5 V/4 A.

For 6 V/5 A the connection of the green wires to the transformer has to be changed as indicated in fig. 7.

If lamps of 9 V/4 A are used, this has to be mentioned in the order as the necessary changes have to be made in the factory.

**Fan(s)**

Behind the control panel of the output-amplifier rack there is a fan; for the connection of its transformer see fig. 8.

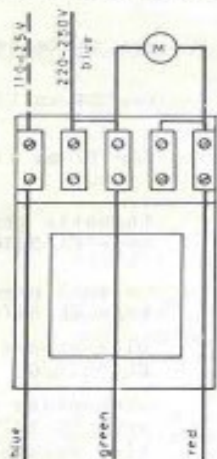

Fig. 8

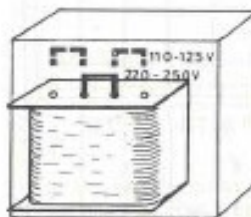

Fig. 9

In the tropics-version of the output-amplifier rack (EL 5374/10) there is, moreover, a ventilating unit EL 5486/00; for the connection of the transformer of this unit see fig. 9.

**Pick-up pre-amplifier**

At the component-side of the print plate there are two tags marked M and two tags marked X.

For magneto-dynamic pick-ups, tags M have to be interconnected.

For crystal pick-ups, tags X have to be interconnected.

If not indicated otherwise in the order, the equipment is supplied with tags X interconnected.

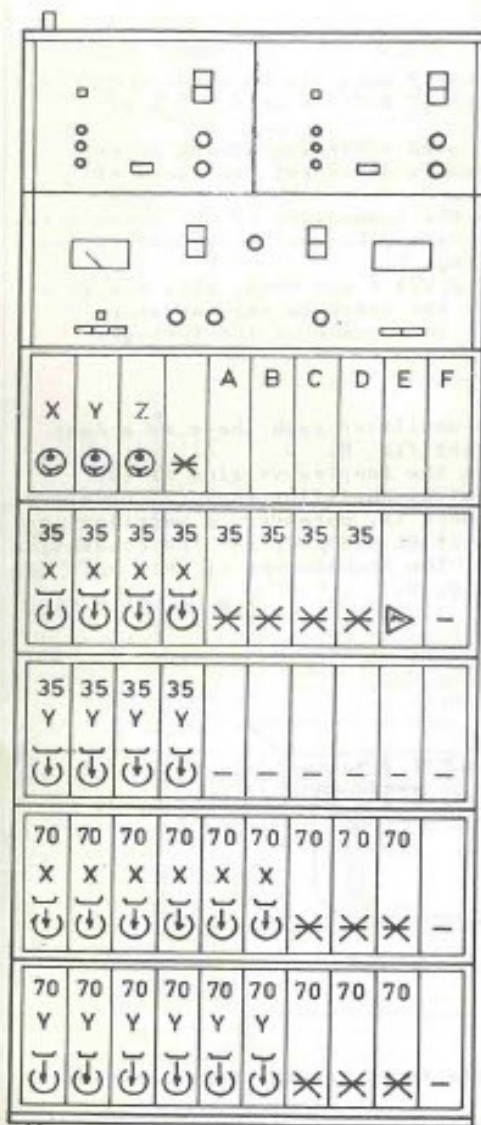

Fig. 10

- X = projector X
- Y = projector Y
- Z = projector Z (only optical)
- A...F = see table below
- 35 = for 35-mm films
- 70 = for 70-mm films
- = magnetic pre-amplifiers type EL 5470/00
- = optical pre-amplifiers type EL 5471/00
- = pick-up pre-amplifiers EL 5472/00
- = microphone pre-amplifiers type EL 5473/00, also suitable for tape recorder or gong
- = 12-kc/s unit type EL 5474/00
- = filter units type EL 5475/00
- = blind panel

	A	B	C	D	E
EL 5373/20					-
EL 5373/21					-
EL 5373/22	-	-			
EL 5373/23					
EL 5373/24					
EL 5373/25					



### ELECTRICAL CONNECTIONS

. Connect the cables as indicated in fig. 1.

#### Attention!

. The pre-amplifier rack can be supplied in the versions /20.../25 with different units at the places A, C and E (fig. 10).

The input terminals for the units are:

at place A ..... 42U-41U

at place C ..... 42V-41V

at place E ..... 42W-41W

To these terminals can be connected, depending on the version used:

- EL 5373/20: 42U-41U = record player  
42V-41V = microphone\*) or gong or Mono recorder  
42W-41W = not used
- EL 5373/21: 42U-41U = record player } or Stereo record player  
42V-41V = record player }  
42W-41W = not used
- EL 5373/22: 42U-41U = not used  
42V-41V = microphone\*) or gong or Mono recorder } or Stereo  
42W-41W = microphone\*) or gong or Mono recorder } recorder
- EL 5373/23: 42U-41U = microphone\*) or gong or Mono recorder } or Stereo  
42V-41V = microphone\*) or gong or Mono recorder } recorder  
42W-41W = microphone\*) or gong or Mono recorder
- EL 5373/24: 42U-41U = record player  
42V-41V = microphone\*) or gong or Mono recorder } or Stereo  
42W-41W = microphone\*) or gong or Mono recorder } recorder
- EL 5373/25: 42U-41U = record player > or Stereo record player  
42V-41V = record player  
42W-41W = microphone\*)

\*) impedance: 500 Ω

. Near or on each sound source (projector, record player, microphone, etc.) a single-pole push-button with instantaneous make-contact has to be fitted for switching on the relevant channel(s), thereby blocking at the same time all the other channels.

Some projectors are already provided with this button ("change-over" button); it is connected to the terminals 105X-106X or 105Y-106Y in respectively projector X and Y.

When the amplifiers are used with already installed projectors, the existing change-over button, connected to the terminals 103 - 103A - 104 - 104A, has to be replaced by the new one, to be connected to the terminals 105X-106X or 105Y-106Y.

**Note:** The push-button which is connected to the terminals 105 - 106 (without X or Y) serves for blocking all the sound channels, e.g. when leaving the projection booth.

. In contrast with former amplifiers, the new output amplifiers contain no cross-over network. The advantage is that now a two-core cable is sufficient for the connection between power amplifiers and loudspeaker assemblies behind the screen, whereas formerly a three-core cable had to be used, which might lead to confusion between the cores for the treble and the bass notes.

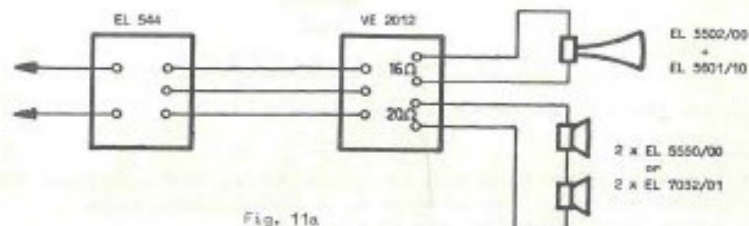

Fig. 11a

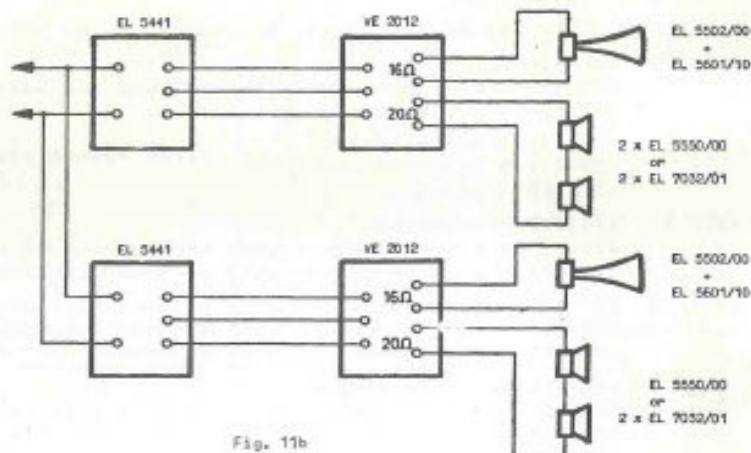

Fig. 11b

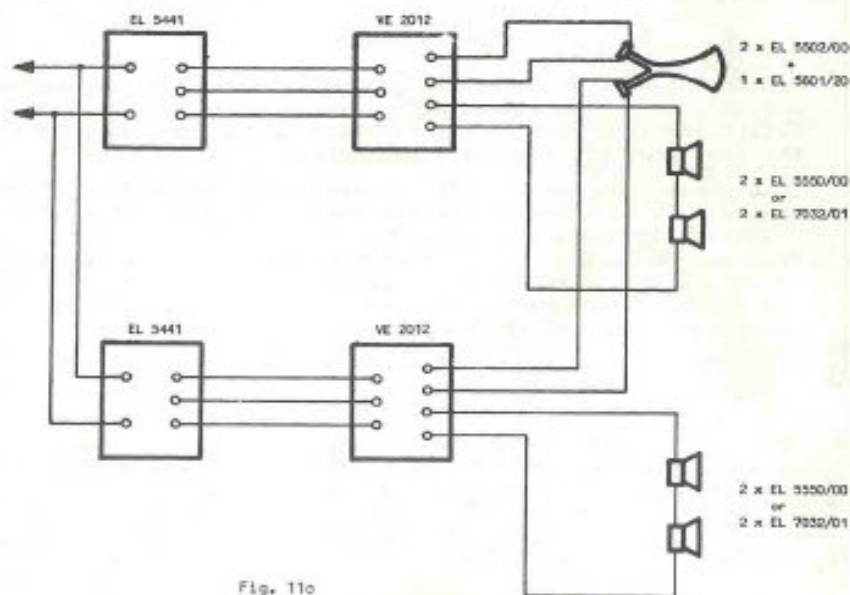

Fig. 11c



Recommended cross-over network (to be mounted e.g. on the loudspeaker baffle): type 5441.

For a loudspeaker assembly consisting of one treble unit and two bass units one cross-over network is sufficient (fig. 11a); for a loudspeaker assembly consisting of two single or one double treble unit and four bass units two cross-over networks have to be used (figs. 11b and 11c).

- As separate monitor loudspeakers can be used:  
2 x EL 7023/00 = 10-W loudspeaker with 100-V transformer.
- If possible all the screened cables have to be passed through conduits or laid in cable ducts, separated from the supply cables.  
Recommended single-core, double-screened cable: type R 287KA/02AA0.
- If the projectors are not yet provided with an automatic system-selector switch (70 mm/35 mm magnetic / 35 mm optical) they have as yet to be equipped with it; the type number is EL 4215. For mounting see page 14.

#### CONNECTION OF A STEREO RECORD PLAYER OR A STEREO RECORDER

**Note:** When connecting a Stereo record player or a Stereo recorder see that the stereo sound is reproduced by the correct loudspeaker groups (either those for channels 5 and 6 or those for channels 1 and 3).

#### Connection of a Stereo record player

(only possible with the pre-amplifier racks EL 5373/21 and /25)

For reproduction via channels 5 and 6 proceed as follows:

- connect the terminals 77U - E77 and 75U - E75;
- connect the terminals 77V - F77 and 75V - F75;
- remove the connections between the terminals 77S - 77U and 77S - 77V and 75S - 75U and 75S - 75V;
- do not remove the connections between the terminals 77S - B77M and 75S - B75M.

For reproduction via channels 1 and 3 proceed as follows:

- connect the terminals 77U - A77M - A77 and 75U - A75M - A75;
- connect the terminals 77V - C77M - C77 and 75V - C75M - C75;
- remove the connections between the terminals 77S - 77U and 77S - 77V and 75S - 75U and 75S - 75V;
- do not remove the connections between the terminals 77S - B77M and 75S - B75M.

#### Connection of a Stereo recorder

(only possible with the pre-amplifier racks EL 5373/22, /23, /24)

With the racks EL 5373/22 and EL 5373/24 channels V and W (see page 5) have to be used (connection as for case c below).

With rack EL 5373/23 can be used optionally:

- a) channels U + V      b) channels U + W      c) channels V + W

For reproduction via the channels 5 and 6 proceed as follows:

- in case a connect the terminals 77U - E77, 75U - E75, 77V - F77, 75V - F75;
- in case b connect the terminals 77U - B77, 75U - E75, 77W - F77, 75W - F75;
- in case c connect the terminals 77V - E77, 75V - E75, 77W - F77, 75W - F75;
- remove the connections of terminal 77S to 77U, 77V or 77W and of terminal 75S to 75U, 75V or 75W;
- do not remove the connections between the terminals 77S - B77M and 75S - B75M.



- For reproduction via the channels 1 and 3 proceed as follows:
- . in case a connect the terminals 77U-A77M-A77, 75U-A75M-A75, 77V-C77M-C77, 75V-C75M-C75;
  - . in case b connect the terminals 77U-A77M-A77, 75U-A75M-A75, 77W-C77M-C77, 75W-C75M-C75;
  - . in case c connect the terminals 77V-A77M-A77, 75V-A75M-A75, 77W-C77M-C77, 75W-C75M-C75;
  - . remove the connections of terminal 77S to 77U, 77V or 77W and of terminal 75S to 75U, 75V or 75W;
  - . do not remove the connections between the terminals 77S-B77M and 75S-B75M.



CONTROLS, etc.

CONTROL PANELS of the  
PRE-AMPLIFIER and OUTPUT-AMPLIFIER RACKS

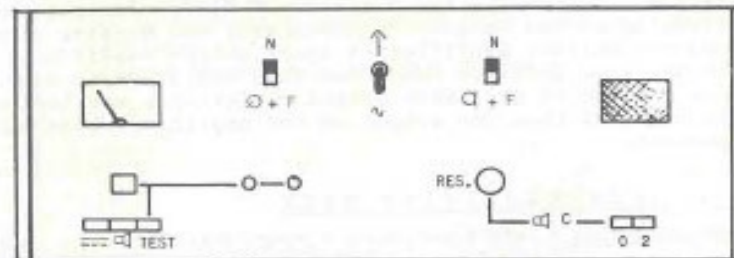

With the exception of the mains switch and of the switches N/O+F and N/C+F which are not on the control panel of the output-amplifier rack, the control panels of both racks are equipped with:

- . a measuring instrument for checking the various voltages and currents;
- . a push-button  $\equiv$  for checking the d.c. voltages and currents, e.g. the supply voltage and the exciter-lamp current;
- . a push-button  $\square$  for checking the output voltages of the output amplifiers;
- . a push-button TEST (with pilot lamp) for testing the various amplifiers with the aid of the 1000-c/s signal supplied by the built-in oscillator/measuring amplifier;
- . a push-button for checking the oscillator/measuring amplifier; when this button is pressed, the meter should indicate 0 dB;
- . a potentiometer with screwdriver adjustment for adjusting the oscillator/measuring amplifier;
- . a switch N/O+F (normal / film picture + sound from record player)
- . a switch N/C+F (normal / film picture + sound from microphone or tape recorder)
- . a mains switch  $\sim$ ;
- . a push-button 0<sup>+</sup> for checking the output amplifiers separately with the aid of the meter or the monitor loudspeakers (the built-in as well as the separate ones); the button MON on the relevant output amplifier has then to be pressed;
- . a push-button 2<sup>+</sup> for monitoring continuously the output amplifier of the second channel (channel B) with the aid of the meter or the monitor loudspeakers; no button on this amplifier need to be pressed for this purpose;
- . a volume control VOL<sup>++</sup> for controlling the sound intensity of the monitor loudspeakers;
- . a monitor loudspeaker.

Note:

- . The pre-amplifier rack and the output-amplifier rack are switched on and off simultaneously by means of the mains switch on the pre-amplifier rack.
- . Push-button  $\equiv$  on the output-amplifier rack serves only for measuring the supply voltage for the oscillator/measuring amplifier.

<sup>+</sup> } See page 10.  
<sup>++</sup> }



- \*) The buttons 0 and 2 on the pre-amplifier rack are inactive and can stand in any position; they are intended for installations with pre-amplifier units and output-amplifier units housed in one rack.
- \*\*) Volume control VOL on the output-amplifier rack
  - . has to be turned clockwise (in direction of C) for controlling the sound intensity of the monitor loudspeakers; the monitor signal comes from the monitor amplifier (= spare output amplifier);
  - . has to be set into position RES. when this amplifier is used as a substitute for one of the other output amplifiers; monitoring then takes place direct from the output of the amplifier whose button MON is pressed.

UNITS of the PRE-AMPLIFIER RACK

On the power-supply units (left-hand unit = spare unit):

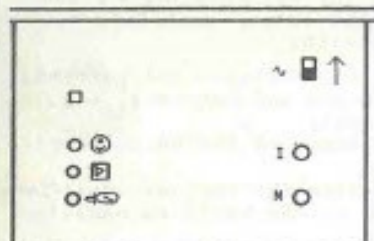

- . a push-button for measuring the stabilised photocell voltage;
- . a push-button for measuring the supply voltages for all the pre-amplifier and filter units;
- . a push-button for measuring the exciter-lamp current;
- . a yellow pilot lamp which lights up when the mains voltage of the unit is switched on;
- . a mains switch  $\sim$ ;
- . a potentiometer I with screwdriver adjustment for adjusting the exciter-lamp current;
- . a potentiometer M with screwdriver adjustment for calibrating the measuring circuit of the exciter-lamp current.

On the pre-amplifier units:

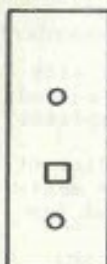

- . a potentiometer with screwdriver adjustment for adjusting the output voltage;
- . a pilot lamp which lights up when the unit is switched on;
- . a push-button for testing the unit.

The colours of the pilot lamps are different; they are:  
 on the optical pre-amplifier units ..... white  
 on the magnetic pre-amplifier units ..... red  
 on the microphone pre-amplifier units ..... green  
 on the pick-up pre-amplifier units ..... purple

On the filter units:



- . a treble control H;
- . a bass control B;
- . a yellow pilot lamp which lights up when one of the pre-amplifier units connected to it is in operation;
- . a push-button for testing the unit.



On the 12 kc/s unit:

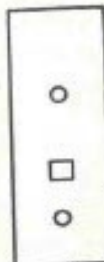

- . a potentiometer with screwdriver adjustment for adjusting the sensitivity;
- . an orange pilot lamp which lights up when the unit is switched on;
- . a push-button for testing the unit.

UNITS of the OUTPUT-AMPLIFIER RACK

On the output-amplifier units:

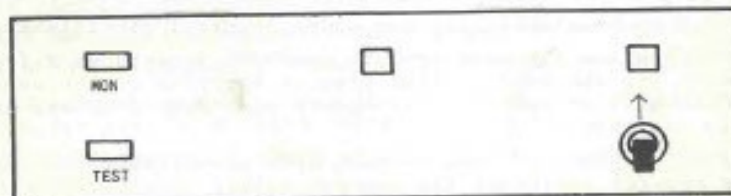

- . a push-button MON for testing the output voltage of the unit;
- . a push-button TEST for checking the operation of the unit and its gain with the aid of the 1000-c/s signal;
- . a mains switch  $\sim$  with orange pilot lamp;
- . a white pilot lamp, supplied by the output voltage of the relevant unit, the light intensity of this lamp being a directive for the output power.



## CHECKING and ADJUSTMENT

### SUPPLY VOLTAGES AND CURRENTS

- . Press button on the control panel of the pre-amplifier rack.
- . Press consecutively on the right-hand supply unit:
  - button = photocell voltage
  - button = supply voltage for the pre-amplifier units, the filter units and the oscillator/measuring amplifier
  - button = exciter-lamp current; switch on the relevant exciter lamp by means of the "change-over" button on the projector.

In all these cases the meter should indicate approx. 0 dB.  
Release the button after checking.

Note: The exciter-lamp supply (ordered by the client) can be:

- 5 V - 4 A } suitable for use under tropical conditions
- 9 V - 4 A }
- 6 V - 5 A - not suitable for use under tropical conditions

For calibrating the exciter-lamp current, proceed as follows:

- . remove the short-circuiting plug at the rear of the supply unit and connect an ammeter ( impedance max. 0.2 Ω ) to the now available sockets;
- . adjust the exciter-lamp current with potentiometer I so that the ammeter indicates the correct value;
- . press button and adjust potentiometer M so that the built-in meter indicates approx. 0 dB;
- . insert the short-circuiting plug again.

### OSCILLATOR/MEASURING AMPLIFIER

- . Press button TEST on the control panel of the pre-amplifier rack.
- . Press the button next to the potentiometer with screwdriver adjustment; the meter must indicate approx. 0 dB; if not, turn the potentiometer until the indication is 0 dB.

### GAIN AND OPERATION OF THE VARIOUS AMPLIFIERS

- . Press button TEST on the control panel of the pre-amplifier rack.
- . Press consecutively the push-buttons of all the pre-amplifier and filter units; the meter must always indicate approx. 0 dB.
- . Press button TEST on the control panel of the output-amplifier rack.
- . Press consecutively the push-buttons TEST on all the output-amplifier units; the meter of the output-amplifier rack must indicate approx. 0 dB.

Note: NEVER CHECK THE AMPLIFIERS WHEN THERE ARE PATRONS IN THE HALL.

CHECK THE PRE-AMPLIFIERS ONLY WHEN THEY ARE NOT IN OPERATION  
(i.e. make sure that the pilot lamps are not alight).

### ADJUSTMENT OF THE SOUND

- . Put all the mains switches into their "on" position.



For 35-mm films with optical sound proceed as follows:

- . Turn the knob on the remote volume-control box to position 8.
  - . Thread a 50 % modulated<sup>+</sup>) frequency-testfilm into projector X.
  - . Turn the potentiometer of the first optical pre-amplifier from the left fully anti-clockwise.
  - . Set the tone controls B and H of the filter unit next to the three optical pre-amplifiers at their centre position<sup>++</sup>).
  - . Press the buttons and 2 on the control panel of the output-amplifier rack.
  - . Start projector X and press its "change-over" button.
  - . Turn the potentiometer on the optical pre-amplifier so that at 1000 c/s the meter of the output-amplifier rack indicates 0 dB.
- Repeat the above with the other projector.

For 35-mm films with magnetic sound proceed as follows:

- . Turn the knob on the remote volume-control box to position 8.
- . Thread a 50 % modulated<sup>+</sup>) frequency-test film into projector X.
- . Turn the potentiometers on the four magnetic pre-amplifiers for projector X and for 35-mm films fully anti-clockwise.
- . Set the tone controls B and H of the relevant filter units at their centre position<sup>++</sup>).
- . Press the buttons and 0 on the control panel of the output-amplifier rack.
- . Start projector X and press its "change-over" button.
- . Press at the test frequency of 1000 c/s consecutively the buttons MON of the output amplifiers A, B, C, D and turn the potentiometers on the magnetic pre-amplifiers until the meter on the output-amplifier rack indicates 0 dB.

Repeat the above with the other projector.

For 70-mm films (with six-channel magnetic sound) proceed as follows:

- . Turn the knob on the remote volume-control box to position 8.
- . Thread a 50 % modulated<sup>+</sup>) frequency-testfilm into projector X.
- . Turn the potentiometers of the six magnetic pre-amplifiers for projector X and for 70-mm films fully anti-clockwise.
- . Set the tone controls B and H of the relevant filter units at their centre position<sup>++</sup>).
- . Press the buttons and 0 on the control panel of the output-amplifier rack.
- . Start projector X and press its "change-over" button.
- . Press at the test frequency of 1000 c/s consecutively the buttons MON on the output amplifiers A, B, C, D, E, F and turn the potentiometers on the magnetic pre-amplifiers until the meter on the output-amplifier rack indicates 0 dB.

Repeat the above with the other projector.

+ ) = 6 dB below 100 %.

++ ) Later on, these controls have to be set as required by the acoustics of the hall and the quality of the sound recorded on the film.



DIRECTIONS for MOUNTING and ADJUSTMENT  
of the AUTOMATIC SYSTEM-SELECTOR SWITCH  
in the 70/35-mm PROJECTOR

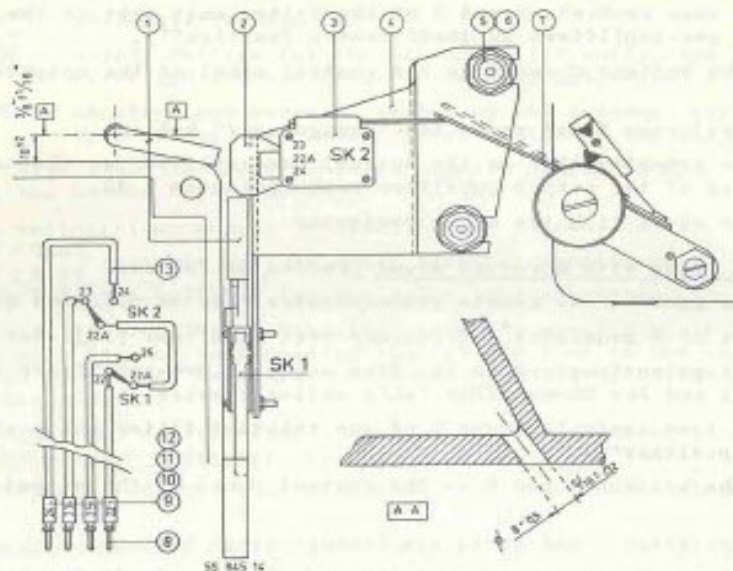

**MOUNTING and ADJUSTMENT**

- . Take the film strippers with their shafts from the two upper sprockets.
- . Remove the pivoting lever with roller and pointer of the magnetic soundhead.
- . Fix strip "7" under the screw of the pointer.
- . Remove the protection plate of the shutter housing and push aside the connecting cables of the framing lamp.
- . Drill a hole with a dia. of 8 mm (5/16") from the rear of the projector into the wall of the shutter housing (see figure).
- . Mount the unit consisting of the components 1, 2, 3, 8, 9, 10, 11, 12, 13 with the aid of the new stripper shafts "5" and "6".
- . Pass the connecting cables marked 22, 23, 24, 25 through the just made hole and fix them, together with the cables of the framing lamp, against the wall of the shutter housing. Then pass them via the existing conduit in the projector and connect them to the terminals 22, 23, 24, 25 of the terminal strip in the projector base.

**Note:** If there are not yet terminals marked 24 and 25, take for the relevant wires two free terminals and mark them.

The terminals 22 and 23 exist always. If switch "70-35" of the projector is connected to them, remove this switch and the cables.



- . Mount the film strippers again.
- . Adjust the pointer on the lower of the two sprockets; take care of the rod of the film-rupture device.
- . Mount the pivoting lever + roller + pointer again and see that the spring tension is about 400 g (14 oz).
- . Bend strip "7" so that SK2 changes over when the roller on the pivoted lever touches the stop.
- . Bend the lever of SK1 so that SK1 changes over when the runner plate for 70-mm films is inserted.

**OPERATION**

- . When the runner plate for 70-mm films is in the projector, terminal 22 is connected to terminal 25 via SK1. Switch SK2 is then inactive.
- . When the runner plate for 35-mm films is in the projector, terminal 22 is connected to contact 22A of SK2 via contact 22A of SK1. When the film has magnetic sound tracks, the pivoted lever with roller is drawn upwards when the film is thread in the magnetic soundhead, by which contact 22A of SK2 is connected to terminal 24. When the film has an optical sound track, contact 22A of SK2 is connected to terminal 23.

**Summary:**

- with 70-mm films ..... terminal 22 connected to 25
- with 35-mm films with magnetic sound ... terminal 22 connected to 24
- with 35-mm films with optical sound ... terminal 22 connected to 23

For the amplifier equipment this signifies that by pressing the "change-over" button on the projector

when 22-25 are connected: the magnetic pre-amplifiers and their filter units for 70-mm films are switched on automatically;

when 22-24 are connected: only the magnetic pre-amplifiers and their filter units for 35-mm film with magnetic sound are switched on automatically;

when 22-23 are connected: only the optical pre-amplifier and its filter unit for 35-mm films with optical sound are switched on automatically.

