

PHILIPS

Cinema Amplifier "M 2", type EL 5341

Introduction

This very modern Philips Cinema Amplifier for optical sound tracks, used in conjunction with Philips loudspeakers, forms the ideal system for sound reproduction in halls with a capacity up to 1500 seats. Its principal features are:

- Greatest reliability.
- Small dimensions.
- Easy installation.
- High output power.
- High sensitivity.
- Minimum distortion, hum and noise.
- Continuously adjustable frequency response.
- Two built-in monitor speakers.
- Simple operation.
- Easy maintenance and service.
- Suitable for use under tropical conditions.

The incorporation of all these features in one amplifier has been made possible by the use of transistors and printed circuits, which in recent years have been adopted more and more in electronic apparatus.



Cinema

Amplifier "M 2", EL 5341



Greatest reliability

Because of their inevitably limited life, valves are the weak point in every amplifier. The pre-amplifying part of this amplifier, however, contains no valves, but only transistors whose life can best be compared to the very long life of resistors.

As, up to the present, transistors for higher powers do not offer special advantages, the output stage of this amplifier has been, as usual, equipped with valves, for which, however, have been chosen the most reliable and modern types, i.e. ECC 83 as phase inverter and two PL 36 as push-pull output valves. The PL 36 is a power pentode of very sturdy construction. In the output stage of this cinema amplifier the anode voltage is hardly one third of the maximum admissible voltage of the valve, which is therefore exceptionally reliable. To restrict the number of valve types — and hence also the required stock of spare valves — the exciter lamp is also fed by a PL 36 valve, employed here as an HF-generator. The HF-supply of the exciter lamp guarantees reproduction which is just as hum-free as the smoothest D. C. supply.

The complete amplifier unit is connected to the wiring in the cabinet by means of two self-centring plug-in connection strips. It can, therefore, be readily replaced by a spare unit. One inexpensive spare unit represents a 100% reserve.

Needless to say, the printed circuits contribute to a high extent to the reliability of the amplifier, fully excluding cable rupture or insulation faults.

Small dimensions

The largest dimension of transistors is not quite $\frac{5}{8}$ " (15 mm). They require no holder. Therefore it was possible to keep the whole amplifier so small that it can easily be mounted against the front wall of the projection room between the two projectors, which is the most convenient place for operation.

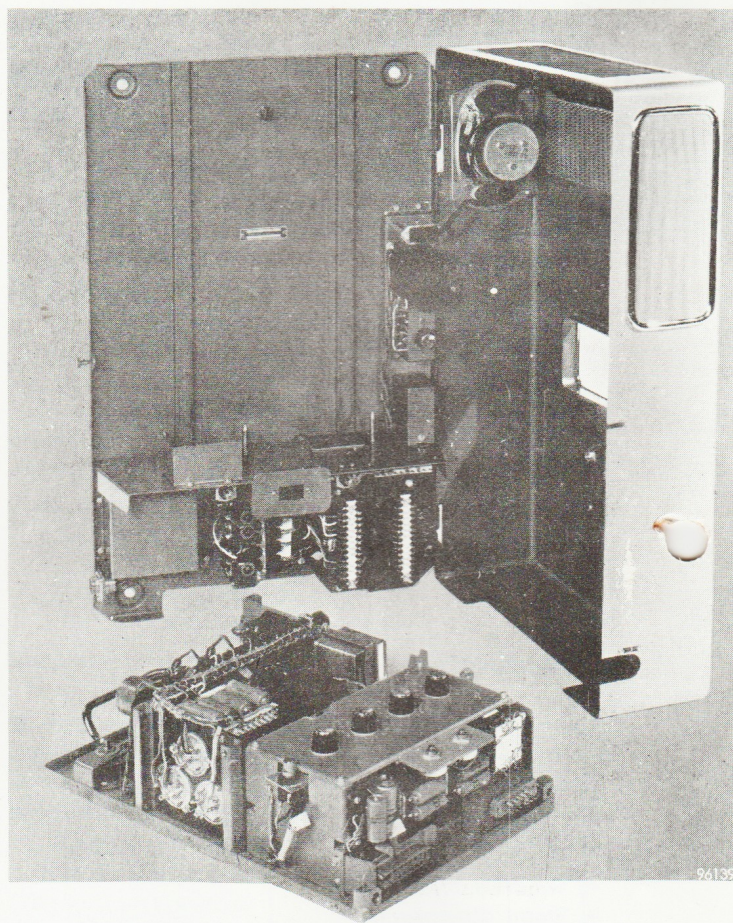
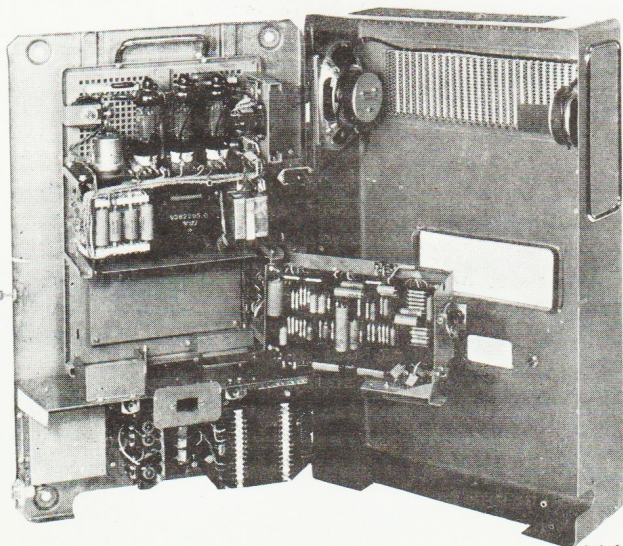

Amplifier unit taken out of the cabinet.

High output power - High sensitivity

Although the amplifier is so small, its output power is quite sufficient for halls with a capacity up to 1500 seats, provided that it is used in conjunction with the Philips loudspeakers for two-way sound reproduction, for which it is intended.

The amplifier has a reserve of 20 dB, i.e. with normal sound tracks it already supplies its full output power when the volume control is only half turned up and even with weakly modulated tracks it is not necessary to turn the volume control up fully.

Minimum distortion, hum and noise

Even at full modulation, the average distortion does not exceed 1%. The noise level is very low — only 5 dB when the volume control is in the working position. Consequently, sound reproduction is really of "Hi-Fi" quality.

Continuously adjustable frequency response

The frequency response can be adapted to the acoustics of the hall and to the frequency response of the recording without any difficulty, by means of the continuously adjustable treble and bass filters. The shaded area in the diagram shows the very large control range.

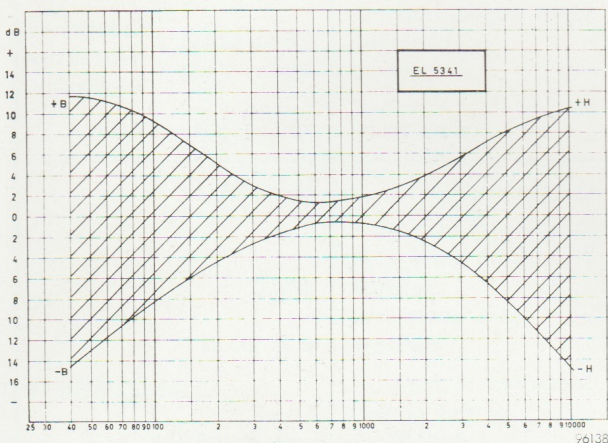

When separate treble and bass reproduction is desired, the amplifier is supplied with a built-in cross-over network; this is equipped with an adjustable treble attenuator for obtaining the ideal balance between treble and bass notes for the hall in question (see diagram).

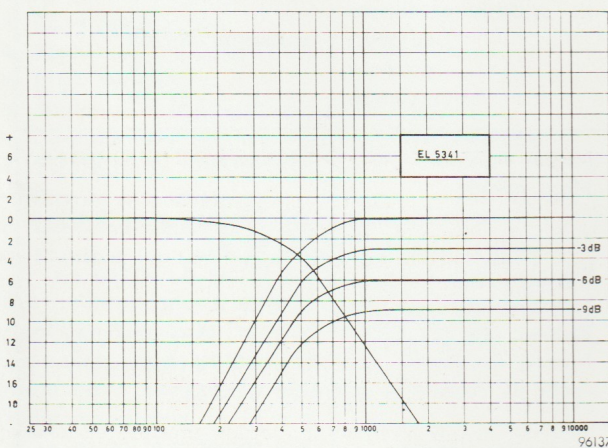

Simple operation

All the controls are easily accessible; those for daily use are assembled on a control panel and accessible when the door is closed, viz., from left to right:

- selector switch for film, microphone or pick-up,
- volume control,
- treble control,
- bass control.

The mains switch, located underneath the control panel, is also accessible when the door is closed; the green and the red lamp to the left and to the right of this switch indicate whether the left or the right-hand projector is connected to the amplifier.

The following controls are accessible when the door is open:

- Change-over switch "C/T" (above the volume control); in position "C" the volume can be controlled in the projection room and in position "T" with the aid of a remote-control box in the hall.
- Two potentiometers (in the middle under the control panel) for adjusting the photocell voltages and hence to compensate the differences in sensitivity of the various photocells.
- Volume control for the monitor loudspeakers (to the right of the control panel) for permanent adjustment of the sound volume desired in the projection room.
- Stand-by switch for the exciter-lamp supply (on the right-hand side of the amplifier unit) for changing over to mains supply in the event of a failure in the HF supply; at the side of this switch there is a mains switch which is normally switched on and which serves only for switching off the amplifier unit separately, e.g. for checking.
- Control for the exciter-lamp supply (at the top left-hand side of the amplifier unit) for reducing the normal supply. By doing so, the overall sensitivity of the amplifier decreases, and the life of the exciter lamp is considerably increased. This is often of advantage in smaller halls where—because of the high sensitivity of the amplifier—only the lower part of the range of the volume control need be used.

In the top right-hand side of the amplifier unit is an easily accessible, dust-tight relay for the change-over of picture and sound from one projector to the other; it is operated by push-buttons on the projectors. The relay changes over simultaneously the supply to the exciter lamps and that to the picture change-over relays of the projectors.

Easy installation

Installation is very simple as this amplifier—like all the other well-known Philips cinema amplifiers—forms a self-contained unit. The housing is fixed with four bolts against the wall of the projection room and the connecting cables are introduced at the bottom or, when they are laid in the wall, at the rear.

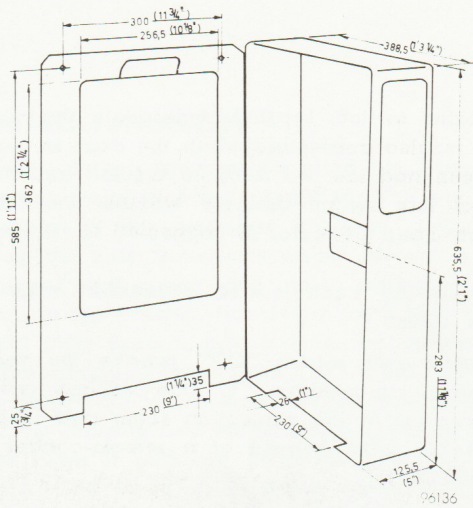

Easy maintenance and service

After the door has been opened, all the valves and other parts are readily accessible, and — due to the printed wiring — neatly arranged (see the photograph showing the amplifier with control panel swung open).

Suitable for use under tropical conditions

For tropical regions, this property is a primary condition, and for non-tropical countries, it is a great advantage because it implies that all the parts are of selected quality.

Type numbers and weights

Type	Description	Net weight
EL 5341/03	Amplifier complete with plug-in amplifier unit and cross-over network	58 lbs 7 ozs 26.5 kg
EL 5341/02	As above, but without cross-over network ...	56 lbs 11 ozs 25.7 kg
EL 5341/01	As above, but without plug-in amplifier unit and without cross-over network	38 lbs 9 ozs 17.5 kg
EL 5440/00	Amplifier unit	18 lbs 2 ozs 8.2 kg
EL 5441/00	Cross-over network ...	1 lb 12 ozs 0.8 kg

Technical data

Input sensitivity (at an output voltage of 100 V across 500 Ω): photocell pick-up microphone	average 0.65 mV " 16.5 mV " 3.75 mV
Input impedance: photocell pick-up microphone	about 23 kΩ } independent of the frequency about 47 kΩ } about 400 Ω - 40 kΩ
Output voltage	max. 100 V
Output impedance: without cross-over network with cross-over network	500 Ω 2 x 500 Ω
Distortion at max. output power: at 1000 c/s at 4000 c/s at 60 c/s	average 0.75 % " 1 % " 1.25 %
Noise level (measured with volume control on "10" and tone control in middle position): photocell pick-up microphone	average -56 dB " -62 dB " -57 dB
Mains voltage	110 and 220 V ~, 50-100 c/s
Max. power consumption	125 W (cos φ = 0.87)
Photocell voltage ..	50 - 97 V
Exciter-lamp supply .	6.5 V/1.48 A; 50,000 c/s
Picture-relay supply .	6 V/4.5 A
Valves, etc.	3 x OC 73 (transistor) 2 x OC 71 (transistor) 1 x ECC 83 3 x PL 36
Inspection lamps ...	2 x 8008N (6.3 V/0.15 A)
Fuses	1 x 08 142 29 (500 mA) 1 x 08 142 33 (1.6 A)

